

# Servo-Electric Grippers

EN-2023.11



# DH-ROBOTICS

DH-Robotics is a high-tech company which focus on providing core components for industrial intelligent manufacturing scenarios. Based on the self-developed precision force control direct drive technology, we provide customers in various industries around the world with diversified electric grippers and precision motion products to reduce production costs, improve production efficiency, and achieve intelligent manufacturing.

## Our Support System



### R&D System



New Technology



Innovation



R&D



Engineering Management



### Sales Network



Projects Assessment



Training



Quality Supervision



After-sales Service



### Manufacturing



Quality System



Stock Management



Supply Management



Manufacturing

# CONTENTS

Applications	5
Selection Reference	8
Products Brief Parameters	10

---

## **PGE Series** Slim-type Electric Parallel Gripper



PGE-2-12	14
PGE-5-26	15
PGE-8-14	16
PGE-15-10	17
PGE-15-26	18
PGE-50-26	19
PGE-50-40	20
PGE-100-26	21

---

## **PGSE Series** Slim-type Electric Parallel Gripper



PGSE-15-7	23
-----------	----

---

## **RGI Series** Electric Rotary Gripper



RGIC-35-12	25
RGIC-100-35	26
RGI-100-14	27
RGI-100-22	28
RGI-100-30	29

---

## **RGD Series** Electric Direct Drive Rotary Gripper



RGD-5-14	31
RGD-5-30	32
RGD-35-14	33
RGD-35-30	34

**PGI Series**  
Electric Parallel Gripper



---

PGI-140-80 36

**PGHL Series**  
Heavy-Load Long-Stroke  
Electric Parallel Gripper



---

PGHL-400-80 38

**PGS Series**  
Miniature Electro-  
magnetic Gripper



---

PGS-5-5 40

**PGC Series**  
Electric Collaborative  
Parallel Gripper



---

PGC-50-35 42  
PGC-140-50 43  
PGC-300-60 44

**AG Series**  
Electric Adaptive Gripper



---

AG-160-95 46  
AG-105-145 47  
DH-3 48

**CG Series**  
Electric Centric Gripper



---

CGE-10-10 50  
CGI-100-170 51  
CGC-80-10 52



# Applications in Cutting-edge Industries

More solutions and applications, please visit [www.dh-robotics.com](http://www.dh-robotics.com)

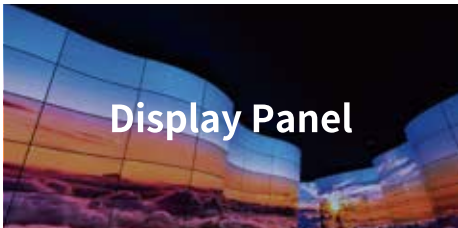
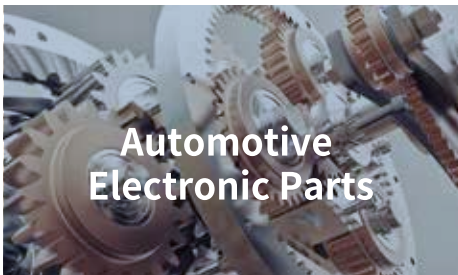
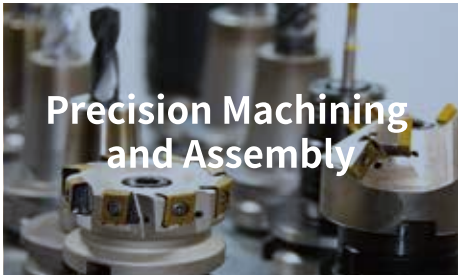
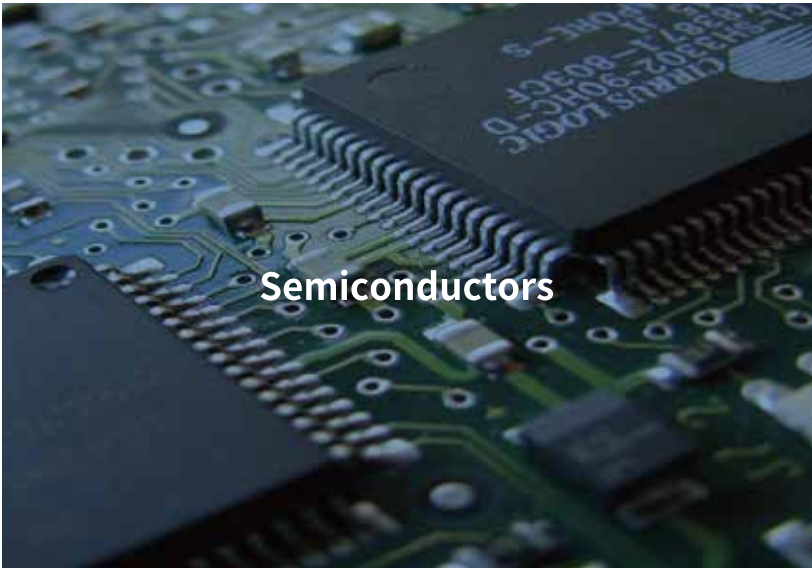

# Application cases



## PGE-8-14 Automatic Application

One collaborative robot with two electric grippers to complete the loading and unloading.

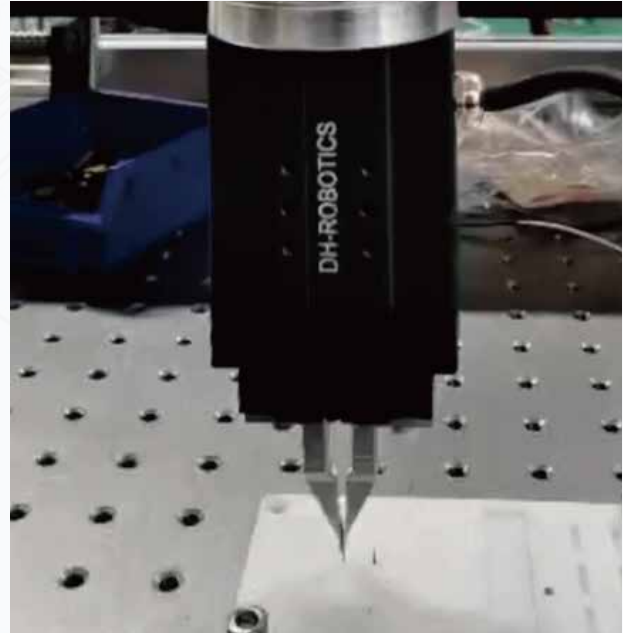

## PGE-8-14 Electronics

Handling and positioning of very small workpieces.



## RGI-35-14 Medical Automation

The automatic sub-cup processing system, through ABB's Scara robotic arm and DH-Robotics electric gripper, can automatically complete the operation of sample tube opening, scanning, information entry, pipetting, turning plate, and closing lid.



## PGE-15-26 Medical Automation

Double-channel scan code to read the information, and unscrew the tube cover. Participate in automatic cup sharing process.



# Application cases



## PGC-50-35 Automation

Two PGC-50-35 grippers were applied with UR robot to pick& place the work-pieces on production line.



## AG-160-95 Automotive

AG-160-95 electric gripper was applied with a collaborative robot to complete the clamping and assembly of needle roller bearings.



## PGC-140-50 Robot New Retail

The PGC-140-50 was applied with DOOSAN robot to complete a show in CHANEL stores located in 20 countries to celebrate the 100th anniversary of CHANEL No. 5 perfume.



## AG-160-95 Machining

The AG-160-95 electric gripper was applied with AGV and COBOT to complete machine tool loading and unloading and machine tool equipment management.







## Short wire correspondence table

Our gripper can directly connect to the end interface of each brand of collaborative robot through a short wire.  
(The serial number represent the short wire type.)

Support electric gripper models	UR CB Series	UR E Series	Elite CS Series	SIASUN	Hanwha A Series	ROKAE CR Series	DOBOT CR Series	DOBOT Nova Series	Aubo	Elephant	Jaka	ECHMAN	ROKAE SR Series	ROKAE ER Series	DOBOT MG400	UR E Series	Doosan A Series	Doosan M Series	Elite EC Series	Han's Robot	Neuromeka	FAIRNO	Hanwha HCR	UF xArm
Small current electric gripper (Peak current ≤ 0.6A)	01																							
Small current electric gripper (Peak current < 1.5A)		01	01	01	01				02	03	04	05	06	06	07									
High current electric claw (Peak current > 1.5A)																08								
In common (Support large and small current electric gripper)						01	01	01									09	10	11	12	13	14	15	16

## DH-Robotics' Gripper and Cylinder Communication Protocol Conversion Box

The communication within DH-Robotics' Servo Gripper and Servo Electric Cylinder defaults to Modbus RTU (RS485) and a small number of I/O. If customers choose other communication protocols, they will need to use the communication protocol conversion box. The following communication protocol conversion boxes are available for selection:

	Communication Protocol Conversion Box Name	Ordering Model		Communication Protocol Conversion Box Name	Ordering Model
	EtherCAT 1-1	M2E-B1-1		TCP/IP 1-1	M2T-B1-1-YBT
	EtherCAT 1-4	M2E-B1-4		PROFINET 1-2	M2P2-B1-2-HJ
	EtherCAT转 I/O 1-More	Please contact our technical staff confirm the specific parameters		PROFINET 1-11	M2P-B1-11-9

## Quick Selection Reference

According to the following five conditions, you can quickly and initially select the matching gripper model; or you can also consult sales for detailed understanding and selection.

### Condition 1 Application



- Collaborative robot
  - Load
  - Peak current
- Industrial robot
- Automation module

### Condition 2 Workpiece weight



- Workpiece shape
- Workpiece material
- Friction
- ...

### Condition 3 Gripping stroke



- Workpiece size
- Parallel / centric
- Outer clip, inner support
- Fingertip design
- ...

### Condition 4 Feature selection



- Rotary
- Self-locking
- Envelope grab
- ...

### Condition 5 Environmental requirements



- IP class
- Temperature conditions
- ...

# Host Computer Debugging Software (PC Side)

## User-friendly

The host computer debugging software was self-developed by DH-Robotics, it can help customers easily and quickly complete various function parameters adjustments, testing and initialization setting on the PC side. At the meaning time, various status information is provided in real time, which can save a lot of production line setup time and reduce the difficulty of operation and maintenance for on-site engineers.

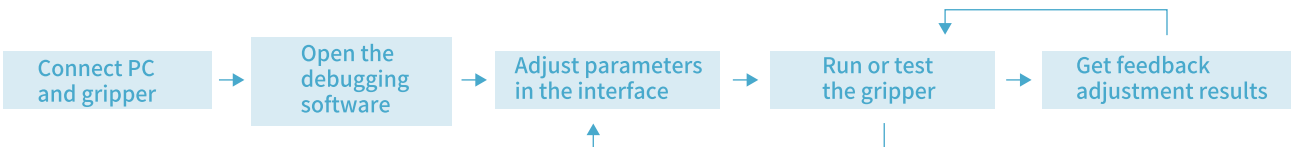

## Parameters Adjustable

- gripping force
- fingertip position
- gripping speed
- rotation angle\*
- rotation speed\*
- rotation force(torque force)\*

## Real-time feedback

- four gripping states
  - ① movement status
  - ② in place
  - ③ clamp state
  - ④ dropped state
- location versus time graph
- clamping current as a function of time

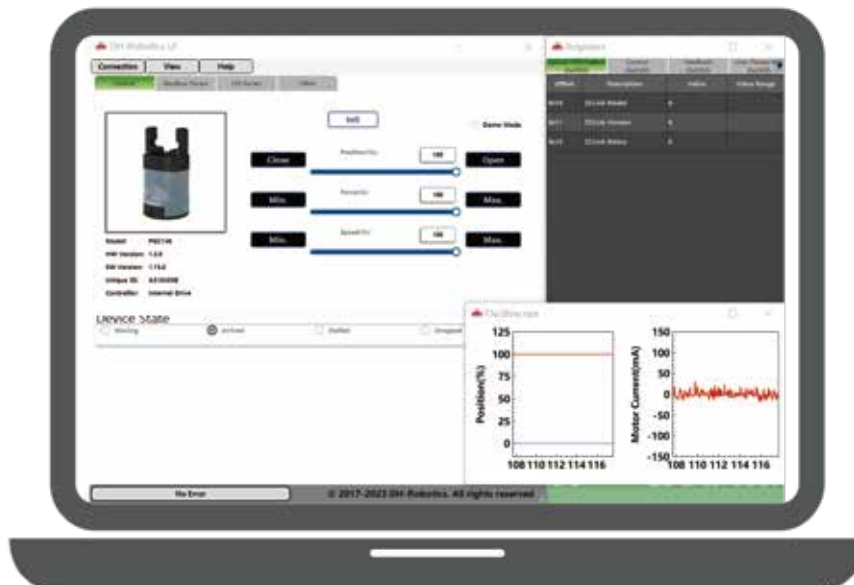

Example: DH-Robotics PC software

\* Please consult sales person for specific applicable models



# Products Brief Parameters

## PGE Series Slim-type Electric Parallel Gripper

Precision force control

Small Size

Fast Response



All-in-one Design

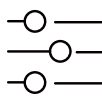

Adjustable Parameters



Intelligent Feedback



Replaceable Fingertip



Self-locking Mechanism

	Gripping Force (N)	Recommended workpiece weight(kg)	Stroke (mm)	Opening/closing time(s)	IP Class
PGE-2-12	0.8~2	0.05	12	0.15	IP40
PGE-5-26	0.8~5	0.1	26	0.3	IP40
PGE-8-14	2~8	0.1	14	0.3	IP40
PGE-15-10	6~15	0.25	10	0.3	IP40
PGE-15-26	6~15	0.25	26	0.5	IP40
PGE-50-26	15~50	1	26	0.45	IP40
PGE-50-40	15~50	1	40	0.45	IP40
PGE-100-26	30~100	2	26	0.5	IP40

## PGSE Series Slim-type Electric Parallel Gripper

Small Size

Fast Response



All-in-one Design



Replaceable Fingertip



PGSE-15-7

	Gripping Force (N)	Recommended workpiece weight(kg)	Stroke (mm)	Opening/closing time(s)	IP Class
PGSE-15-7	6~15	0.25	7	0.15	IP40

## RGI Series Electric Rotary Gripper

Infinite  
Rotation



All-in-one  
Design

Dual Servo  
System

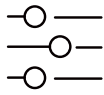

Adjustable  
Parameters

Compact  
Type



Intelligent  
Feedback



Replaceable  
Fingertip



RGIC-35-12



RGIC-100-35



RGI-100-14



RGI-100-22



RGI-100-30

	Gripping Force (N)	Recommended workpiece weight(kg)	Stroke (mm)	Opening/closing time(s)	IP Class
RGIC-35-12	13~35	0.5	12	0.6	IP40
RGIC-100-35	40~100	1	35	0.9	IP40
RGI-100-14	30~100	1.5	14	0.6	IP40
RGI-100-22	30~100	1.5	22	0.65	IP40
RGI-100-30	30~100	1.5	30	0.7	IP40

## RGD Series Electric Direct Drive Rotary Gripper

Zero  
Backlash



All-in-one  
Design

Infinite  
Rotation

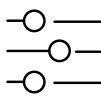

Adjustable  
Parameters

Precise  
Positioning



Intelligent  
Feedback



Replaceable  
Fingertip



Self-locking  
Mechanism



RGD-5-14



RGD-5-30



RGD-35-14



RGD-35-30

	Gripping Force (N)	Recommended workpiece weight(kg)	Stroke (mm)	Opening/closing time(s)	IP Class
RGD-5-14	2~5.5	0.05	14	0.5	IP40
RGD-5-30	2~5.5	0.05	30	0.5	IP40
RGD-35-14	10~35	0.35	14	0.5	IP40
RGD-35-30	10~35	0.35	30	0.7	IP40

## PGI Series Electric Parallel Gripper

High Load

High Protection Grade

Long Stroke



All-in-one Design

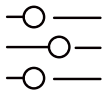

Adjustable Parameters



Intelligent Feedback



Replaceable Fingertip



Self-locking Mechanism



PGI-140-80

	Gripping Force (N)	Recommended workpiece weight(kg)	Stroke (mm)	Opening/closing time(s)	IP Class
PGI-140-80	40~140	3	80	1.1	IP54

## PGHL Series Heavy-Load Long-Stroke Electric Parallel Gripper

High Load

High Protection Grade

Long Stroke



All-in-one Design

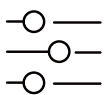

Adjustable Parameters



Intelligent Feedback



Replaceable Fingertip



Self-locking Mechanism



PGHL-400-80

	Gripping Force (N)	Recommended workpiece weight(kg)	Stroke (mm)	Opening/closing time(s)	IP Class
PGHL-400-80	140~400	8	80	1.0/1.1	IP40

## PGS Series Miniature Electro-magnetic Gripper

Small Size

High Frequency

Easy Operation



Replaceable Fingertip



Self-locking Mechanism



PGS-5-5

	Gripping Force (N)	Recommended workpiece weight(kg)	Stroke (mm)	Opening/closing time(s)	IP Class
PGS-5-5	3~5.5	0.05	5	0.03	IP40

## PGC Series Electric Collaborative Parallel Gripper

Plug and Play

High Protection Grade

High Load



All-in-one Design

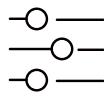

Adjustable Parameters



Intelligent Feedback



Replaceable Fingertip



Self-locking Mechanism



PGC-50-35



PGC-140-50



PGC-300-60

	Gripping Force (N)	Recommended workpiece weight(kg)	Stroke (mm)	Opening/closing time(s)	IP Class
PGC-50-35	15~50	1	37	0.7	IP54
PGC-140-50	40~140	3	50	0.6	IP67
PGC-300-60	80~300	6	60	0.8	IP67

## AG Series Electric Adaptive Gripper

Plug and Play

Envelope Adaptive Gripping

Long Stroke



All-in-one Design

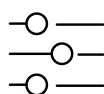

Adjustable Parameters

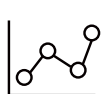

Intelligent Feedback



Replaceable Fingertip



Self-locking Mechanism



AG-160-95



AG-105-145



DH-3

	Gripping Force (N)	Recommended workpiece weight(kg)	Stroke (mm)	Opening/closing time(s)	IP Class
AG-160-95	45~160	3	95	0.9	IP54
AG-105-145	35~105	2	145	0.9	IP54
DH-3	10~65	1.8	106(parallel)/122(centric)	0.7	IP40

## CG Series Electric Centric Gripper

Centric Gripping



All-in-one Design

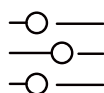

Adjustable Parameters

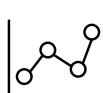

Intelligent Feedback



Replaceable Fingertip



Self-locking Mechanism



CGE-10-10



CGE-100-170



CGC-80-10

	Gripping Force (N)	Recommended workpiece weight(kg)	Stroke (mm)	Opening/closing time(s)	IP Class
CGE-10-10	3~10	0.1	10 (Single jaw)	0.3	
CGI-100-170	30~100	1.5	φ40~φ170 (Inward workpiece diameter)	0.5	IP40
CGC-80-10	20~80	1.5	10 (Single jaw)	0.2	IP67

# PGE Series Slim-type Electric Parallel Gripper

PGE-2-12      PGE-15-26  
PGE-5-26      PGE-50-26  
PGE-8-14      PGE-50-40  
PGE-15-10     PGE-100-26



The PGE series is an industrial slim-type electric parallel gripper. With its precise force control, compact size and highly working speed, it has become a “Hot sell product” in the field of industrial electric gripper.

## Installation



1. Front installation: use front screw holes for installation
2. Rear installation: use rear screw holes for installation
3. Right installation: use right screw holes for installation
4. Left installation: use left screw holes for installation
5. Bottom installation : use bottom screw holes for installation

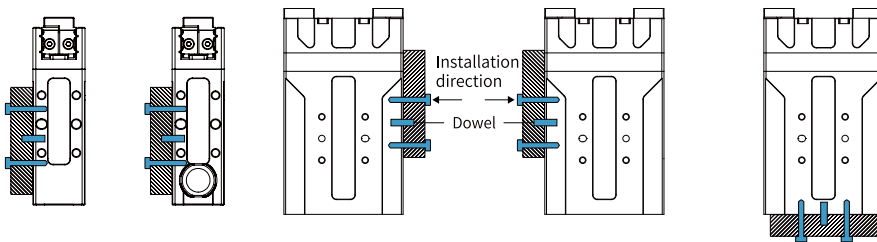

## Product Features

### ● Small size Flexible Installation

The thinnest size is 18 mm with compact structure, supports at least five flexible installation methods to meet the needs of clamping tasks & saves design space.

### ● High Working Speed

The fastest opening and closing time can reach 0.15 s / 0.15 s, which can meet the high-speed and stable clamping requirements of the production line.

### ● Precise Force Control

With special driver design and driving algorithm compensation, the gripping force is continuously adjustable, and the force repeatability could reach 0.1 N.



## Application

For scenarios requiring force control or flexibility, such as assembly, sorting and loading and unloading in semiconductor, 3C electronics, medical automation and other industries.



# PGE-2-12

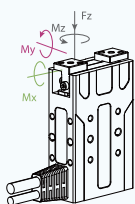

## Static Vertical Allowable Load

**Fz** 35 N

## Allowable Loading Moment

**Mx** 0.2 N·m

**My** 0.17 N·m

**Mz** 0.2 N·m

\*① It depends on the shape of the grasping object, the material and friction of the contact surface, and the acceleration of the motion, if you have any questions, please contact us.

\*② Use optional communication, need external communication conversion box, please consult the sales staff for details

## Parameters

### Product Parameter

Gripping force (per jaw)	0.8~2 N
Stroke	12 mm
Recommended workpiece weight *①	0.05 kg
Opening/closing time	0.15 s/0.15 s
Repeat accuracy (position)	± 0.02 mm
Noise emission	< 50 dB
Weight	0.15 kg
Driving method	Rack and pinion + Cross roller guide
Size	Gripper Size: 65 mm x 39 mm x 18 mm Controller Size: 78 mm x 52.4 mm x 27.2 mm

### Working Environment

Communication interface	Standard: Modbus RTU (RS485), Digital I/O Optional: TCP/IP, USB2.0, CAN2.0A, PROFINET, EtherCAT *②
Rated voltage	24 V DC ± 10%
Rated current	0.2 A
Peak current	0.5 A
IP class	IP 40
Recommended environment	0~40°C, under 85% RH
Certification	CE, FCC, RoHS

×	●	●	●	●	×
Built-in Controller	Gripping Force Adjustable	Position Adjustable	Speed Adjustable	Drop Detection	Self-locking Mechanism

## Technical Drawings

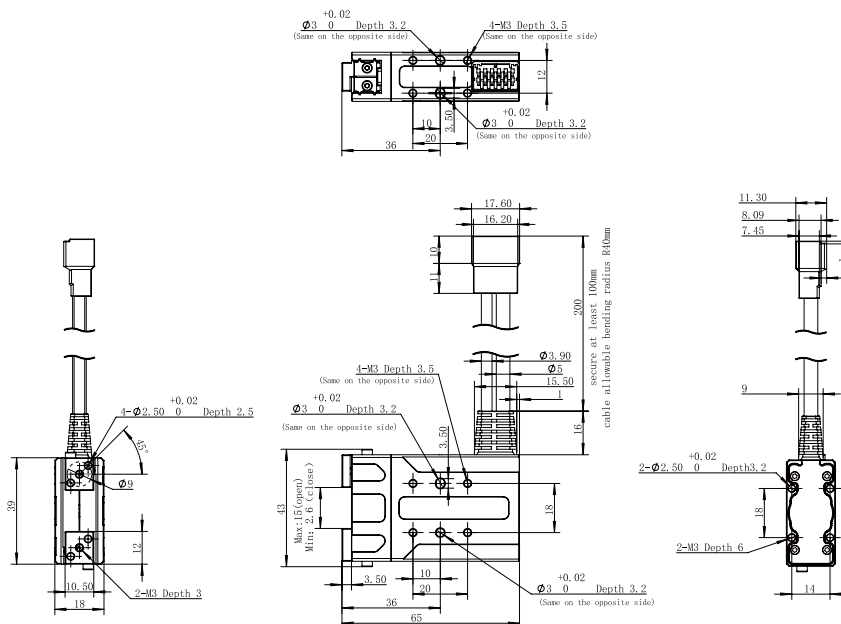

# PGE-5-26

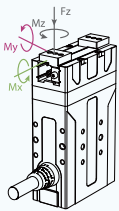

## Static Vertical Allowable Load

**Fz** 50 N

## Allowable Loading Moment

**Mx** 0.3 N·m

**My** 0.25 N·m

**Mz** 0.3 N·m

\*① It depends on the shape of the grasping object, the material and friction of the contact surface, and the acceleration of the motion, if you have any questions, please contact us.

\*② Use optional communication, need external communication conversion box, please consult the sales staff for details

## Parameters

### Product Parameter

Gripping force (per jaw)	0.8~5 N
Stroke	26 mm
Recommended workpiece weight *①	0.1 kg
Opening/closing time	0.3 s/0.3 s
Repeat accuracy (position)	± 0.02 mm
Noise emission	< 50 dB
Weight	0.4 kg
Driving method	Rack and pinion + Cross roller guide
Size	95 mm x 55 mm x 26 mm (without brake) 113.5 mm x 55 mm x 30 mm (with brake)

### Working Environment

Communication interface	Standard: Modbus RTU (RS485), Digital I/O Optional: TCP/IP, USB2.0, CAN2.0A, PROFINET, EtherCAT *②
Rated voltage	24 V DC ± 10%
Rated current	0.4 A
Peak current	0.7 A
IP class	IP 40
Recommended environment	0~40°C, under 85% RH
Certification	CE, FCC, RoHS

<input checked="" type="checkbox"/> Built-in Controller	<input checked="" type="checkbox"/> Gripping Force Adjustable	<input checked="" type="checkbox"/> Position Adjustable	<input checked="" type="checkbox"/> Speed Adjustable	<input checked="" type="checkbox"/> Drop Detection	<input checked="" type="checkbox"/> Self-locking Mechanism
---	---	---	--	--	--

## Technical Drawings

This drawing is for the gripper without the brake. If you need the drawing for the gripper with the brake, please download it from our official website or contact our sales.

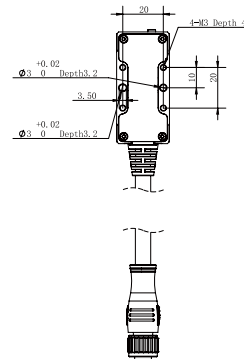
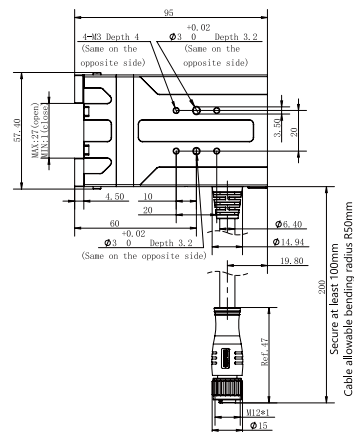
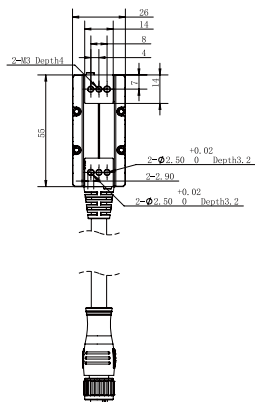
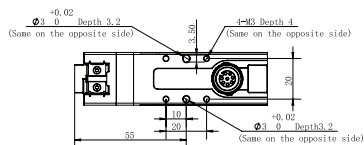

# PGE-8-14

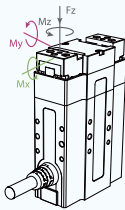

## Static Vertical Allowable Load

**Fz** 90 N

## Allowable Loading Moment

**Mx** 0.55 N · m

**My** 0.45 N · m

**Mz** 0.55 N · m

\*① It depends on the shape of the grasping object, the material and friction of the contact surface, and the acceleration of the motion, if you have any questions, please contact us.

\*② Use optional communication, need external communication conversion box, please consult the sales staff for details

## Parameters

### Product Parameter

Gripping force (per jaw)	2~8 N
Stroke	14 mm
Recommended workpiece weight *①	0.1 kg
Opening/closing time	0.3 s/0.3 s
Repeat accuracy (position)	± 0.02 mm
Noise emission	< 50 dB
Weight	0.4 kg
Driving method	Rack and pinion + Cross roller guide
Size	97 mm x 62 mm x 31 mm

### Working Environment

Communication interface	Standard: Modbus RTU (RS485), Digital I/O Optional: TCP/IP, USB2.0, CAN2.0A, PROFINET, EtherCAT *②
Rated voltage	24 V DC ± 10%
Rated current	0.4 A
Peak current	0.7 A
IP class	IP 40
Recommended environment	0~40°C, under 85% RH
Certification	CE, FCC, RoHS

● Built-in Controller	● Gripping Force Adjustable	● Position Adjustable	● Speed Adjustable	● Drop Detection	× Self-locking Mechanism
-----------------------	-----------------------------	-----------------------	--------------------	------------------	--------------------------

## Technical Drawings

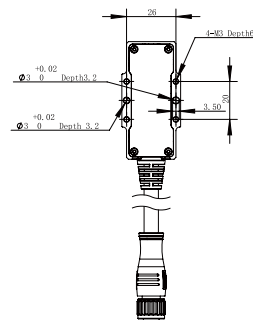
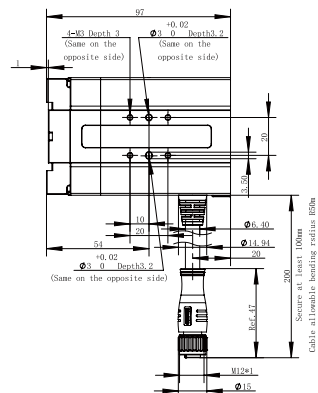
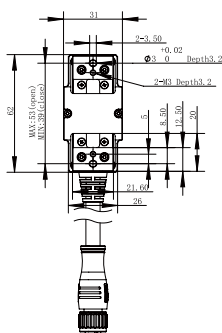
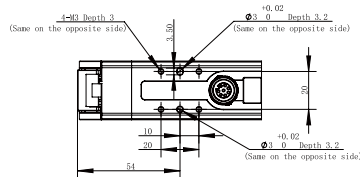

# PGE-15-10

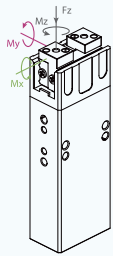

## Static Vertical Allowable Load

Fz 35 N

## Allowable Loading Moment

Mx 0.45 N·m

My 0.4 N·m

Mz 0.45 N·m

\*① It depends on the shape of the grasping object, the material and friction of the contact surface, and the acceleration of the motion, if you have any questions, please contact us.

\*② Use optional communication, need external communication conversion box, please consult the sales staff for details

## Parameters

### Product Parameter

Gripping force (per jaw)	6~15 N
Stroke	10 mm
Recommended workpiece weight *①	0.25 kg
Opening/closing time	0.3 s/0.3 s
Repeat accuracy (position)	± 0.02 mm
Noise emission	< 50 dB
Weight	0.155 kg
Driving method	Precise planetary gears + Rack and pinion
Size	Gripper Size: 89 mm x 30 mm x 18 mm Controller Size: 78 mm x 52.4 mm x 27.2 mm

### Working Environment

Communication interface	Standard: Modbus RTU (RS485), Digital I/O Optional: TCP/IP, USB2.0, CAN2.0A, PROFINET, EtherCAT *②
Rated voltage	24 V DC ± 10%
Rated current	0.1 A
Peak current	0.22 A
IP class	IP 40
Recommended environment	0~40°C, under 85% RH
Certification	CE, FCC, RoHS

× Built-in Controller	● Gripping Force Adjustable	● Position Adjustable	● Speed Adjustable	● Drop Detection	× Self-locking Mechanism
-----------------------	-----------------------------	-----------------------	--------------------	------------------	--------------------------

## Technical Drawings

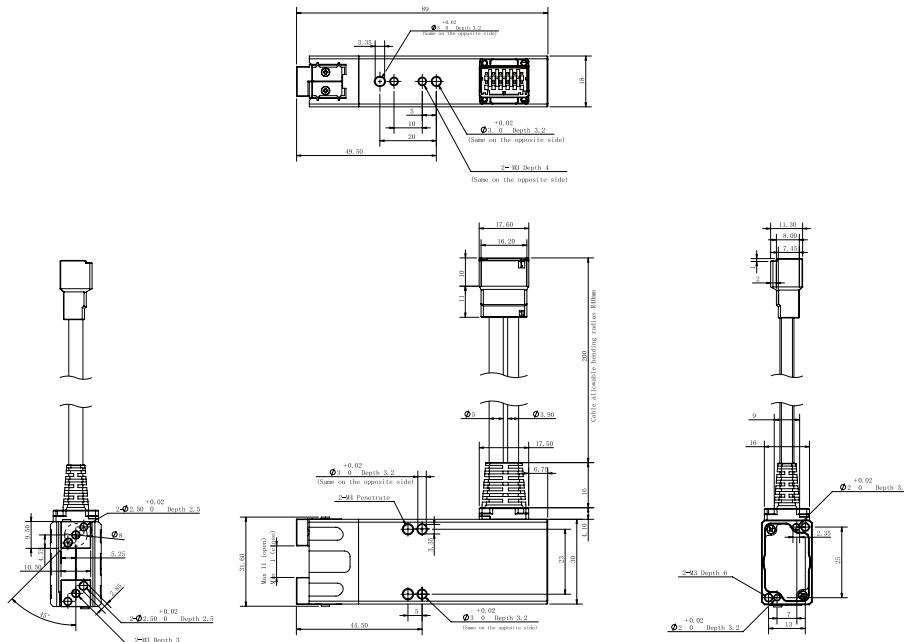

# PGE-15-26

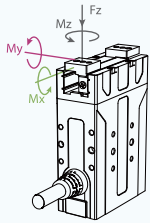

## Static Vertical Allowable Load

**Fz** 70 N

## Allowable Loading Moment

**Mx** 0.9 N·m

**My** 0.75 N·m

**Mz** 0.9 N·m

\*① It depends on the shape of the grasping object, the material and friction of the contact surface, and the acceleration of the motion, if you have any questions, please contact us.

\*② Use optional communication, need external communication conversion box, please consult the sales staff for details

## Parameters

### Product Parameter

Gripping force (per jaw)	6~15 N
Stroke	26 mm
Recommended workpiece weight *①	0.25 kg
Opening/closing time	0.5 s/0.5 s
Repeat accuracy (position)	± 0.02 mm
Noise emission	< 50 dB
Weight	0.33 kg
Driving method	Precise planetary gears + Rack and pinion
Size	86.5 mm x 55 mm x 26 mm (without brake) 107.5 mm x 55 mm x 26 mm (with brake)

### Working Environment

Communication interface	Standard: Modbus RTU (RS485), Digital I/O Optional: TCP/IP, USB2.0, CAN2.0A, PROFINET, EtherCAT *②
Rated voltage	24 V DC ± 10%
Rated current	0.25 A
Peak current	0.5 A
IP class	IP 40
Recommended environment	0~40°C, under 85% RH
Certification	CE, FCC, RoHS

<input checked="" type="checkbox"/> Built-in Controller	<input checked="" type="checkbox"/> Gripping Force Adjustable	<input checked="" type="checkbox"/> Position Adjustable	<input checked="" type="checkbox"/> Speed Adjustable	<input checked="" type="checkbox"/> Drop Detection	<input checked="" type="checkbox"/> Self-locking Mechanism
---	---	---	--	--	--

## Technical Drawings

This drawing is for the gripper without the brake. If you need the drawing for the gripper with the brake, please download it from our official website or contact our sales.

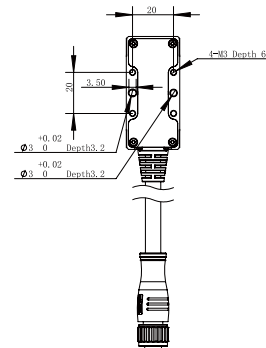
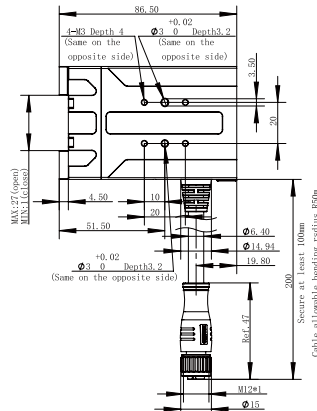
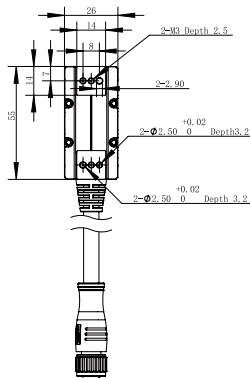
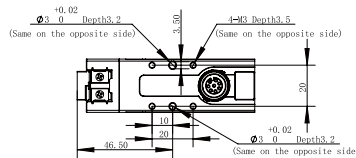



# PGE-50-26

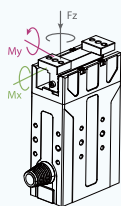

## Static Vertical Allowable Load

**Fz 150 N**

## Allowable Loading Moment

**Mx 2.5 N·m**

**My 2 N·m**

**Mz 3 N·m**

\*① It depends on the shape of the grasping object, the material and friction of the contact surface, and the acceleration of the motion, if you have any questions, please contact us.

\*② Use optional communication, need external communication conversion box, please consult the sales staff for details

## Parameters

### Product Parameter

Gripping force (per jaw)	15~50 N
Stroke	26 mm
Recommended workpiece weight *①	1 kg
Opening/closing time	0.45 s/0.45 s
Repeat accuracy (position)	± 0.02 mm
Noise emission	< 50 dB
Weight	0.4 kg
Driving method	Precise planetary gears + Rack and pinion
Size	97 mm x 55 mm x 29 mm (without brake) 118 mm x 55 mm x 29 mm (with brake)

### Working Environment

Communication interface	Standard: Modbus RTU (RS485), Digital I/O Optional: TCP/IP, USB2.0, CAN2.0A, PROFINET, EtherCAT *②
Rated voltage	24 V DC ± 10%
Rated current	0.25 A
Peak current	0.5 A
IP class	IP 40
Recommended environment	0~40°C, under 85% RH
Certification	CE, FCC, RoHS

<input checked="" type="checkbox"/> Built-in Controller	<input checked="" type="checkbox"/> Gripping Force Adjustable	<input checked="" type="checkbox"/> Position Adjustable	<input checked="" type="checkbox"/> Speed Adjustable	<input checked="" type="checkbox"/> Drop Detection	<input checked="" type="checkbox"/> Self-locking Mechanism
---	---	---	--	--	--

## Technical Drawings

This drawing is for the gripper without the brake. If you need the drawing for the gripper with the brake, please download it from our official website or contact our sales.

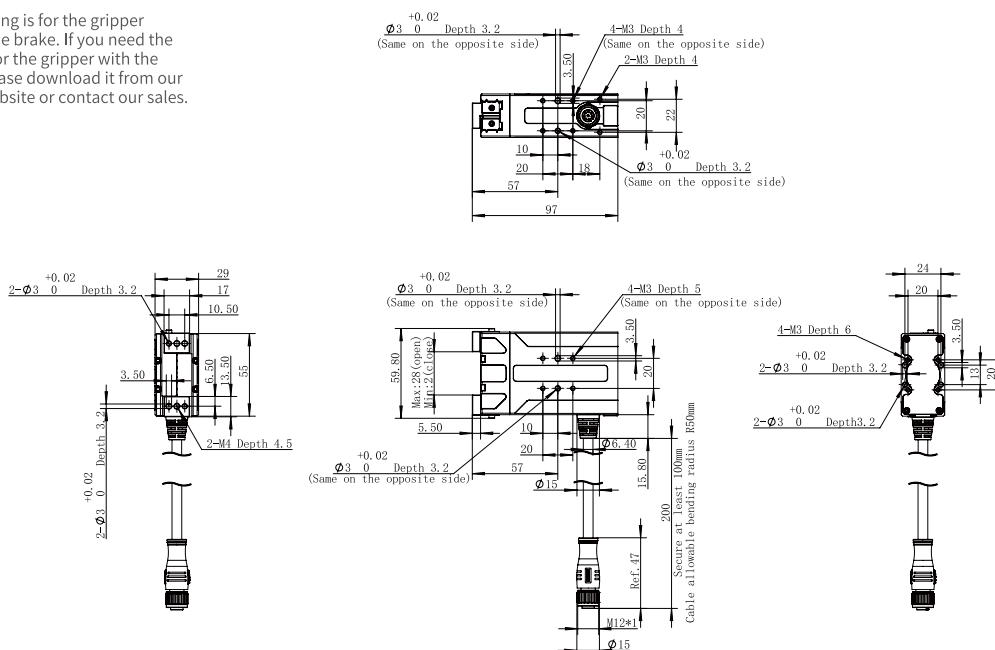

# PGE-50-40

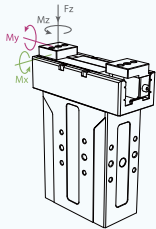

## Static Vertical Allowable Load

**Fz 150 N**

## Allowable Loading Moment

**Mx 2.5 N·m**

**My 2 N·m**

**Mz 3 N·m**

\*① It depends on the shape of the grasping object, the material and friction of the contact surface, and the acceleration of the motion, if you have any questions, please contact us.

\*② Use optional communication, need external communication conversion box, please consult the sales staff for details

## Parameters

### Product Parameter

Gripping force (per jaw)	15~50 N
Stroke	40 mm
Recommended workpiece weight *①	1 kg
Opening/closing time	0.6 s/0.6 s
Repeat accuracy (position)	± 0.02 mm
Noise emission	< 50 dB
Weight	0.51 kg
Driving method	Precise planetary gears + Rack and pinion
Size	97 mm x 78 mm x 29 mm (without brake) 118 mm x 78 mm x 29 mm (with brake)

### Working Environment

Communication interface	Standard: Modbus RTU (RS485), Digital I/O Optional: TCP/IP, USB2.0, CAN2.0A, PROFINET, EtherCAT *②
Rated voltage	24 V DC ± 10%
Rated current	0.25 A
Peak current	0.5 A
IP class	IP 40
Recommended environment	0~40°C, under 85% RH
Certification	CE, FCC, RoHS

●	●	●	●	●	●×
Built-in Controller	Gripping Force Adjustable	Position Adjustable	Speed Adjustable	Drop Detection	Self-locking Mechanism

## Technical Drawings

This drawing is for the gripper without the brake. If you need the drawing for the gripper with the brake, please download it from our official website or contact our sales.

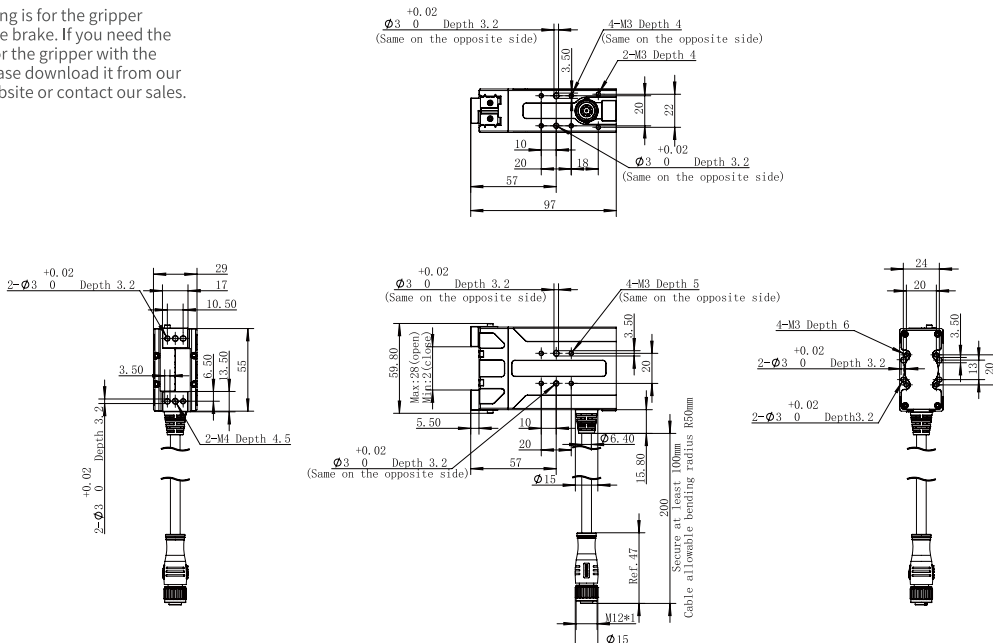

# PGE-100-26

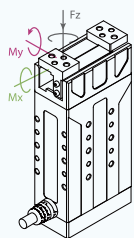

## Static Vertical Allowable Load

**Fz** 150 N

## Allowable Loading Moment

**Mx** 2.5 N·m

**My** 3 N·m

**Mz** 4 N·m

\*① It depends on the shape of the grasping object, the material and friction of the contact surface, and the acceleration of the motion, if you have any questions, please contact us.

\*② Use optional communication, need external communication conversion box, please consult the sales staff for details

## Parameters

### Product Parameter

Gripping force (per jaw)	30~100 N
Stroke	26 mm
Recommended workpiece weight *①	2 kg
Opening/closing time	0.5 s/0.5 s
Repeat accuracy (position)	± 0.02 mm
Noise emission	< 50 dB
Weight	0.55 kg
Driving method	Precise planetary gears + Rack and pinion
Size	125 mm x 57 mm x 30 mm

### Working Environment

Communication interface	Standard: Modbus RTU (RS485), Digital I/O Optional: TCP/IP, USB2.0, CAN2.0A, PROFINET, EtherCAT *②
Rated voltage	24 V DC ± 10%
Rated current	0.3 A
Peak current	1.2 A
IP class	IP 40
Recommended environment	0~40°C, under 85% RH
Certification	CE, FCC, RoHS

<input checked="" type="checkbox"/>	<input checked="" type="checkbox"/>	<input checked="" type="checkbox"/>	<input checked="" type="checkbox"/>	<input checked="" type="checkbox"/>	<input checked="" type="checkbox"/>
Built-in Controller	Gripping Force Adjustable	Position Adjustable	Speed Adjustable	Drop Detection	Self-locking Mechanism

## Technical Drawings

This drawing is for the gripper without the brake. If you need the drawing for the gripper with the brake, please download it from our official website or contact our sales.

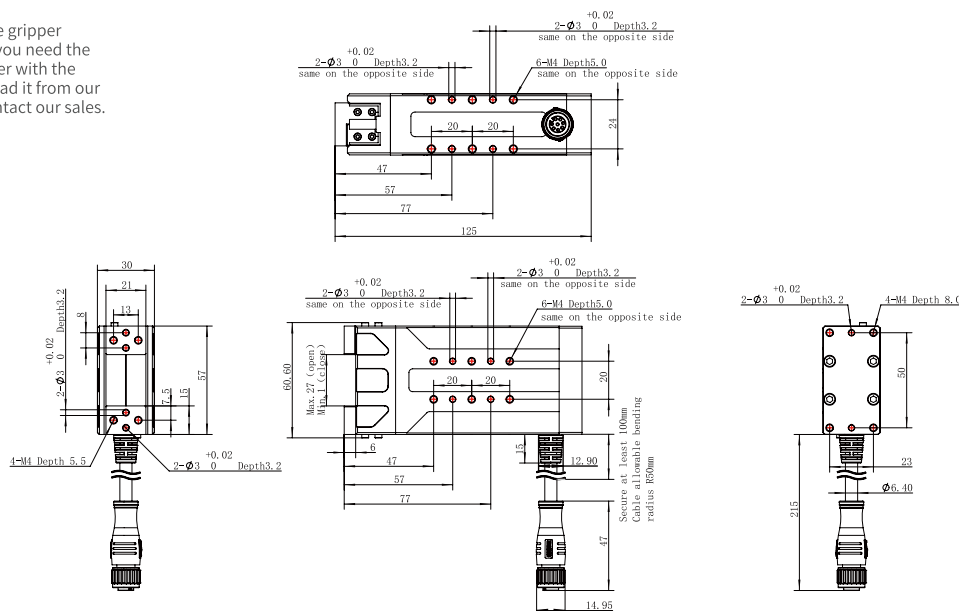

# PGSE Series Slim-type Electric Parallel Gripper

PGSE-15-7



The PGSE Industrial Parallel Gripper is a miniature electric gripper specifically designed to meet the demand for quick grasping in narrow and compact installation spaces in industrial settings.

## Installation



1. Front installation: use front screw holes for installation
2. Rear installation: use rear screw holes for installation
3. Right installation: use right screw holes for installation
4. Left installation: use left screw holes for installation
5. Bottom installation : use bottom screw holes for installation

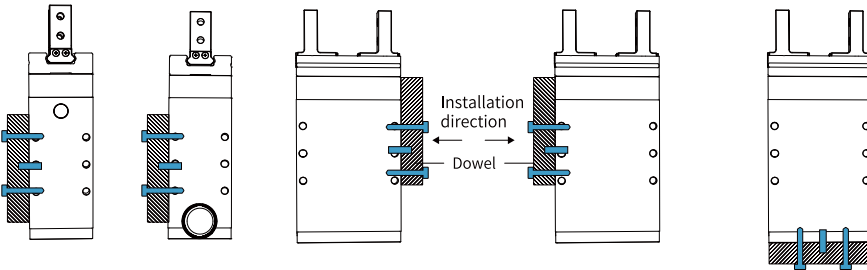

## Product Features

### ● Ultimate Slimness

The PGSE gripper features a compact and intricate design, with dimensions of only 85.6 x 38 x 23.2 mm (length x width x height), making it extremely slim and compact.

### ● High-Speed Response

The PGSE gripper offers rapid opening and closing times, with a minimum response time of as fast as 0.15 seconds for both opening and closing actions. This allows for quick grasping cycles, meeting the high-speed gripping requirements of production lines.

### ● Flexible Installation

The gripper body of the PGSE model provides multiple mounting options, allowing for versatile installation in compact spaces. Coupled with its compact size, it facilitates easy installation in tight spaces.

## Application

The PGSE gripper is suitable for compact production environments, such as the semiconductor and 3C electronics industries, where it can be utilized for gripping, sorting, loading, and unloading of small-sized components.



# PGSE-15-7

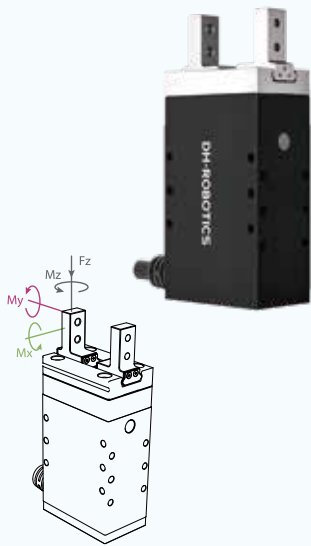

## Static Vertical Allowable Load

**Fz** 70 N

## Allowable Loading Moment

**Mx** 0.9 N·m

**My** 0.75 N·m

**Mz** 0.9 N·m

\*① It depends on the shape of the grasping object, the material and friction of the contact surface, and the acceleration of the motion, if you have any questions, please contact us.

\*② Use optional communication, need external communication conversion box, please consult the sales staff for details

## Parameters

### Product Parameter

Gripping force (per jaw)	6~15 N
Stroke	7 mm
Recommended workpiece weight *①	0.25 kg
Opening/closing time	0.15 s/0.15 s
Noise emission	< 50 dB
Weight	0.15 kg
Driving method	Precise planetary gears + Rack and pinion
Size	85.6 mm x 38 mm x 23.2 mm

### Working Environment

Communication interface	Modbus RTU (RS485)、Digital I/O*②
Rated voltage	24 V DC ± 10%
Rated current	0.15 A
Peak current	0.8 A
IP class	IP 40
Recommended environment	0~40°C, under 85% RH
Certification	CE, FCC, RoHS

●	●	×	×	×	×
Built-in Controller	Gripping Force Adjustable	Position Adjustable	Speed Adjustable	Drop Detection	Self-locking Mechanism

## Technical Drawings

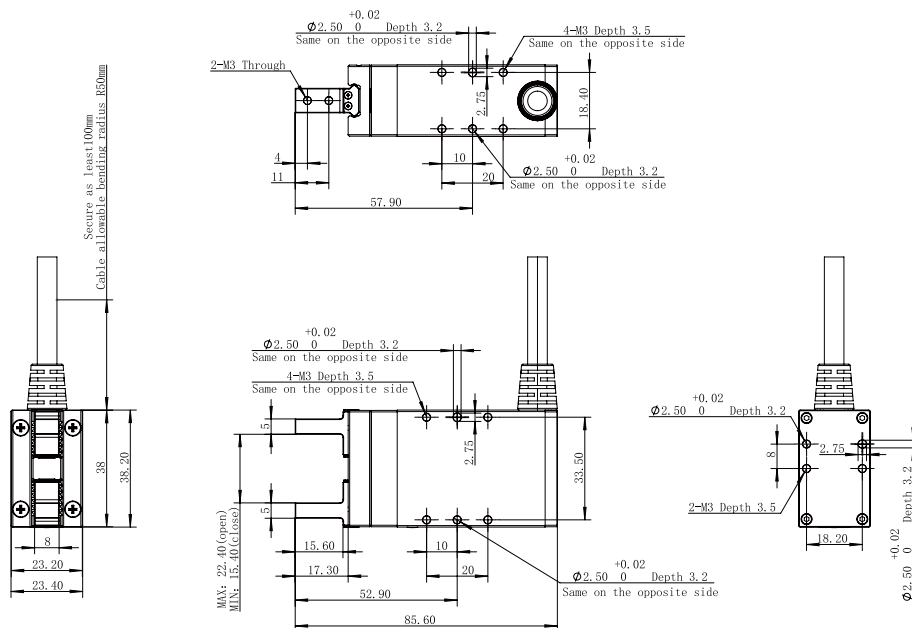



# RGI Series Electric Rotary Gripper

RGIC-35-12 RGI-100-14  
RGIC-100-35 RGI-100-22  
RGI-100-30



RGI series is the first fully self-developed infinite rotating gripper with a compact and precise structure on the market. It is widely applied in medical automation industry to grip and rotate the test tubes as well as other industries like electronics and New energy industry.

## Installation

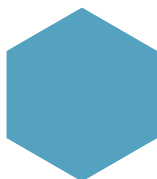

1. Side installation: use side screw holes for installation
2. Bottom installation : use bottom screw holes for installation
3. Rear installation: use rear screw holes for installation
4. Front installation: Install with front screw holes

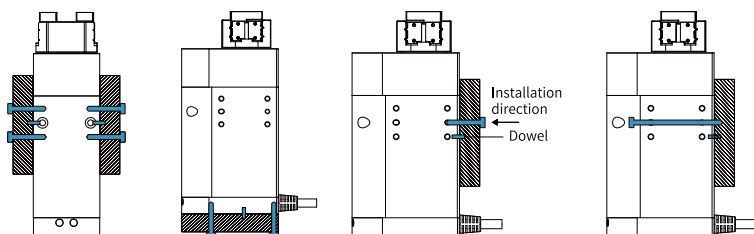

## Product Feature

### ● Gripping & Infinite Rotation

The unique structural design in the industry can realize the simultaneous gripping and infinite rotation on one electric gripper, and solve the winding problem in non-standard design and rotation.

### ● Compact Double Servo System

Dual servo systems are creatively integrated in a thin machine body, which is compact in design and can be adapted to many industrial scenes.

### ● High Gripping Force and Torque

The maximum single-sided gripping force is 100N, and the maximum torque is 1.5N·m. Though precise force control and position control, the RGI gripper can more stably complete the grasping and rotating tasks.

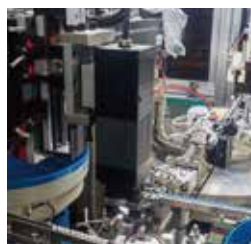

## Application

Medical automation reagents, blood samples, nucleic acids and other sample processing scenarios such as opening and closing covers, scanning code detection, etc.;

RGI-100 series comes standard with fingertips and can be adapted to 10 mix 1 and 20 mix 1 size tubes to meet the needs of large-scale nucleic acid sampling.

# RGIC-35-12

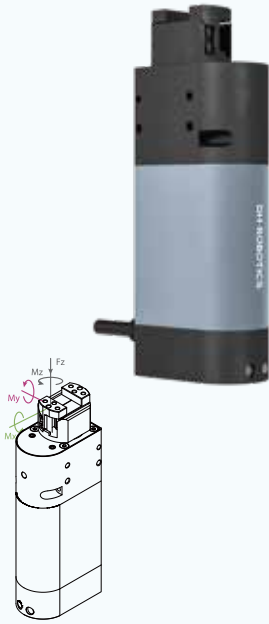

## Static Vertical Allowable Load

**Fz** 100 N

## Allowable Loading Moment

**Mx** 1.5 N·m

**My** 1.1 N·m

**Mz** 2.1 N·m

\*① It depends on the shape of the grasping object, the material and friction of the contact surface, and the acceleration of the motion. If you have any questions, please contact us.

\*② Use optional communication, need external communication conversion box, please consult the sales staff for details

## Parameters

### Product Parameter

Gripping force (per jaw)	13~35 N
Stroke	12 mm
Rated torque	0.2 N·m
Peak torque	0.5 N·m
Rotary range	Infinite Rotating
Recommended workpiece weight *①	0.5 kg
Max. rotation speed	2160 °/s
Repeat accuracy (swiveling)	± 0.05 °
Repeat accuracy (position)	± 0.02 mm
Opening/closing time	0.6 s/0.6 s
Weight	0.64 kg
Size	150 mm x 53 mm x 34 mm Rotary Diameter:33mm

### Working Environment

Communication interface	Standard: Modbus RTU (RS485), Digital I/O Optional: TCP/IP, CAN2.0A, PROFINET, EtherCAT*②
Rated voltage	24 V DC ± 10%
Rated current	1.7 A
Peak current	2.5 A
IP class	IP 40
Recommended environment	0~40°C, under 85% RH
Certification	CE, FCC, RoHS

● Built-in Controller	● Gripping Force Adjustable	● Position Adjustable	● Speed Adjustable	● Drop Detection	● Rotary Adjustable	✗ Self-Locking Mechanism
-----------------------	-----------------------------	-----------------------	--------------------	------------------	---------------------	--------------------------

## Technical Drawings

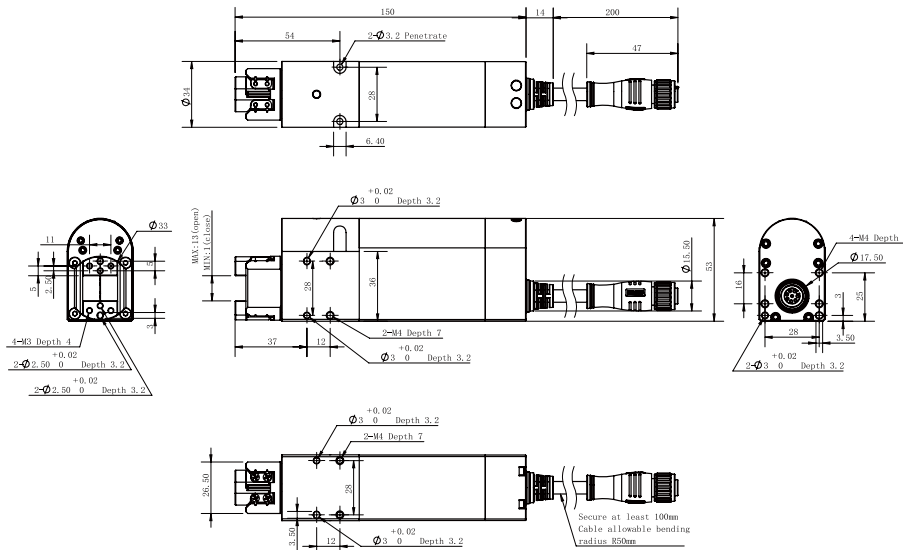

# RGIC-100-35

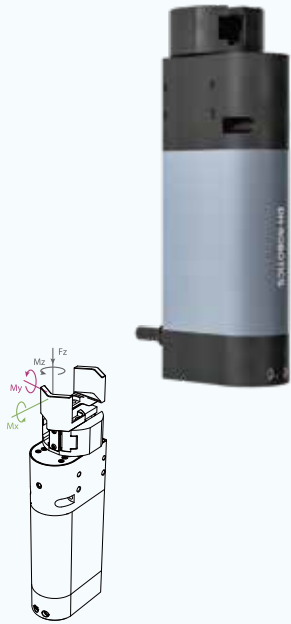

## Static Vertical Allowable Load

**Fz** 200 N

## Allowable Loading Moment

**Mx** 3 N·m

**My** 3 N·m

**Mz** 2.5 N·m

\*① It depends on the shape of the grasping object, the material and friction of the contact surface, and the acceleration of the motion, if you have any questions, please contact us.

\*② Use optional communication, need external communication conversion box, please consult the sales staff for details

## Parameters

Product Parameter	
Gripping force (per jaw)	40~100 N
Stroke	35 mm
Rated torque	0.35 N·m
Peak torque	1.5 N·m
Rotary range	Infinite Rotating
Recommended workpiece weight *①	1 kg
Max. rotation speed	1400 °/s
Repeat accuracy (position)	± 0.02 mm
Opening/closing time	0.9 s/0.9 s
Weight	0.65 kg
Size	159 mm x 53 mm x 34 mm Rotary Diameter:41mm

## Working Environment

Communication interface	Standard: Modbus RTU (RS485) Optimal: TCP/IP, CAN2.0A, PROFINET, EtherCAT* ②					
Rated voltage	24 V DC ± 10%					
Rated current	2.0 A					
Peak current	5.0 A					
IP class	IP 40					
Recommended environment	0~40°C, under 85% RH					
Certification	CE, FCC, RoHS					
● Built-in Controller	● Gripping Force Adjustable	● Position Adjustable	● Speed Adjustable	● Drop Detection	● Rotary Adjustable	✗ Self-Locking Mechanism

## Technical Drawings

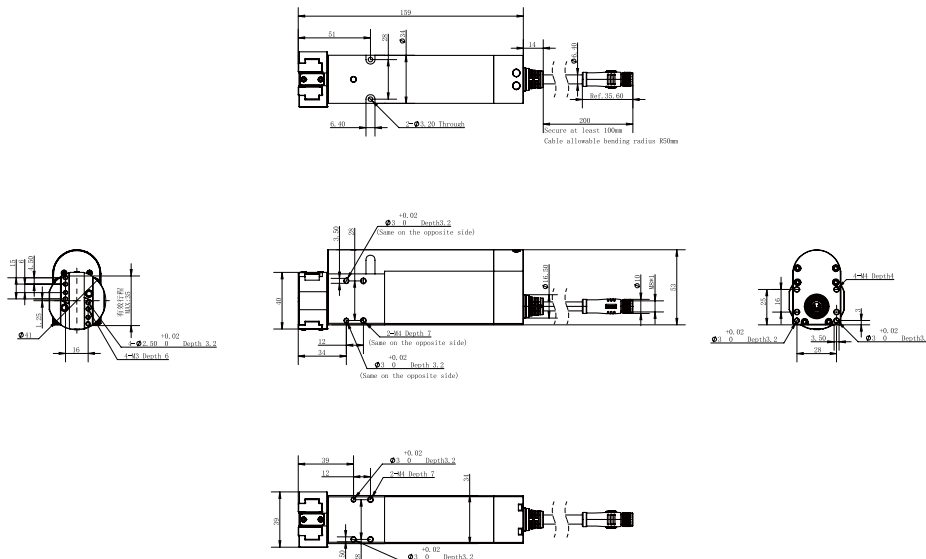

# RGI-100-14



## Static Vertical Allowable Load

**Fz 150 N**

## Allowable Loading Moment

**Mx 2.5 N·m**

**My 3 N·m**

**Mz 4 N·m**

\*① It depends on the shape of the grasping object, the material and friction of the contact surface, and the acceleration of the motion, if you have any questions, please contact us.

\*② Use optional communication, need external communication conversion box, please consult the sales staff for details

## Parameters

### Product Parameter

Gripping force (per jaw)	30~100 N
Stroke	14 mm
Rated torque	0.5 N·m
Peak torque	1.5 N·m
Rotary range	Infinite Rotating
Recommended workpiece weight *①	1.5 kg
Max. rotation speed	2160 °/s
Repeat accuracy (swiveling)	± 0.05 °
Repeat accuracy (position)	± 0.02 mm
Opening/closing time	0.6 s/0.6 s
Weight	1.28 kg
Size	158 mm x 75.5 mm x 47 mm Rotary Diameter: 47.1mm

### Working Environment

Communication interface Standard: Modbus RTU (RS485), Digital I/O  
Optional: TCP/IP, CAN2.0A, PROFINET, EtherCAT \* ②

Rated voltage 24 V DC ± 10%

Rated current 1.0 A

Peak current 4.0 A

IP class IP 40

Recommended environment 0~40°C, under 85% RH

Certification CE, FCC, RoHS

<input checked="" type="checkbox"/>	<input checked="" type="checkbox"/>	<input checked="" type="checkbox"/>	<input checked="" type="checkbox"/>	<input checked="" type="checkbox"/>	<input checked="" type="checkbox"/>	<input checked="" type="checkbox"/>
Built-in Controller	Gripping Force Adjustable	Position Adjustable	Speed Adjustable	Drop Detection	Rotary Adjustable	Self-Locking Mechanism

## Technical Drawings

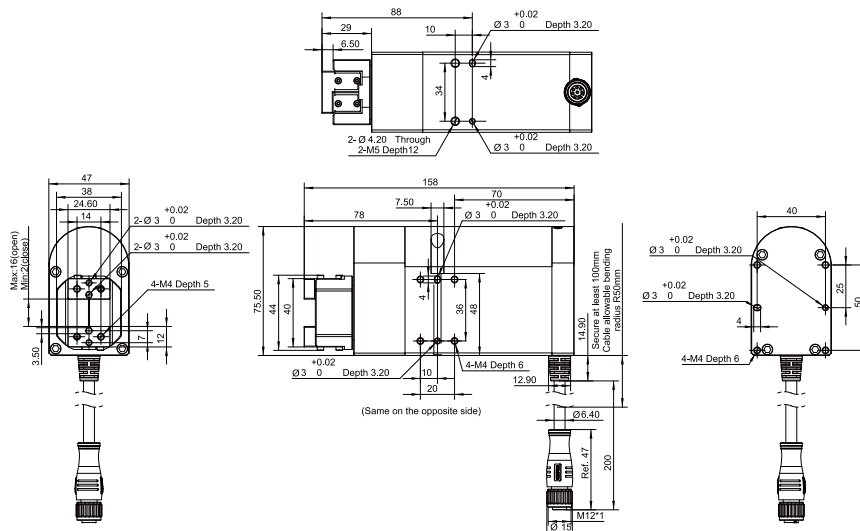

# RGI-100-22



## Static Vertical Allowable Load

Fz 200 N

## Allowable Loading Moment

Mx 3.5 N·m

My 4 N·m

Mz 5.5 N·m

\*① It depends on the shape of the grasping object, the material and friction of the contact surface, and the acceleration of the motion. If you have any questions, please contact us.

\*② Use optional communication, need external communication conversion box, please consult the sales staff for details

## Parameters

### Product Parameter

Gripping force (per jaw)	30~100 N
Stroke	22 mm
Rated torque	0.5 N·m
Peak torque	1.5 N·m
Rotary range	Infinite Rotating
Recommended workpiece weight *①	1.5 kg
Max. rotation speed	2160 °/s
Repeat accuracy (swiveling)	± 0.05 °
Repeat accuracy (position)	± 0.02 mm
Opening/closing time	0.65 s/0.65 s
Weight	1.4 kg
Size	158 mm x 75.5 mm x 47 mm Rotary Diameter:67.1mm

### Working Environment

Communication interface	Standard: Modbus RTU (RS485), Digital I/O Optional: TCP/IP, CAN2.0A, PROFINET, EtherCAT *②
Rated voltage	24 V DC ± 10%
Rated current	1.0 A
Peak current	4.0 A
IP class	IP 40
Recommended environment	0~40°C, under 85% RH
Certification	CE, FCC, RoHS

<input checked="" type="checkbox"/> Built-in Controller	<input checked="" type="checkbox"/> Gripping Force Adjustable	<input checked="" type="checkbox"/> Position Adjustable	<input checked="" type="checkbox"/> Speed Adjustable	<input checked="" type="checkbox"/> Drop Detection	<input checked="" type="checkbox"/> Rotary Adjustable	<input checked="" type="checkbox"/> Self-locking Mechanism
---	---	---	--	--	---	--

## Technical Drawings

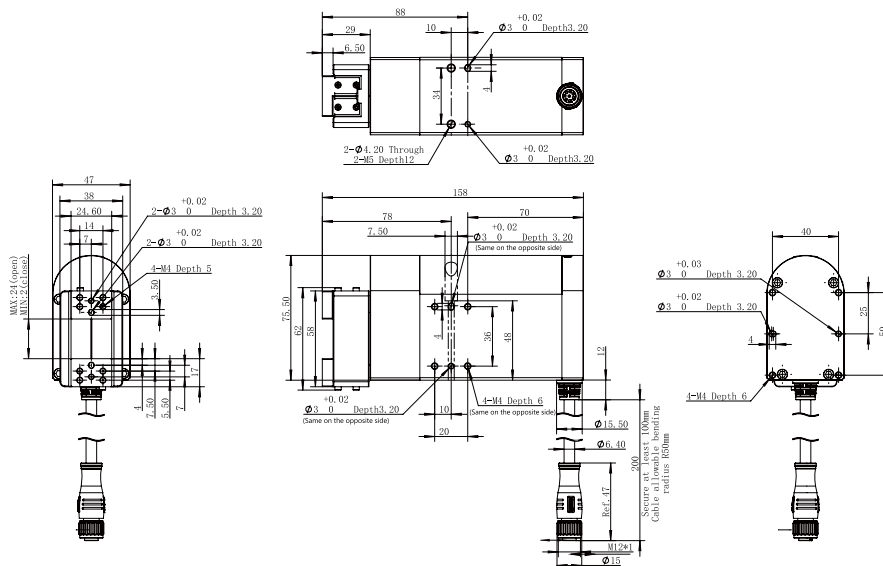

# RGI-100-30

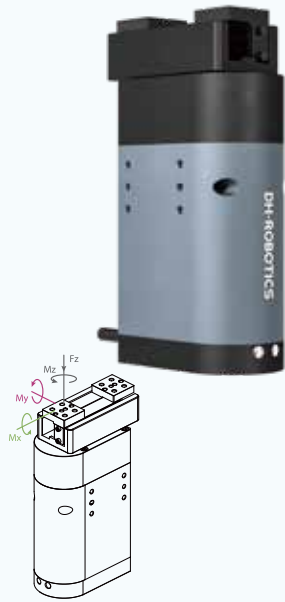

## Static Vertical Allowable Load

**Fz** 250 N

## Allowable Loading Moment

**Mx** 4.5 N · m

**My** 5 N · m

**Mz** 7 N · m

\*① It depends on the shape of the grasping object, the material and friction of the contact surface, and the acceleration of the motion, If you have any questions, please contact us.

\*② Use optional communication, need external communication conversion box, please consult the sales staff for details

## Parameters

### Product Parameter

Gripping force (per jaw)	30~100 N
Stroke	30 mm
Rated torque	0.5 N · m
Peak torque	1.5 N · m
Rotary range	Infinite Rotating
Recommended workpiece weight *①	1.5 kg
Max. rotation speed	2160 °/s
Repeat accuracy (swiveling)	± 0.05 °
Repeat accuracy (position)	± 0.02 mm
Opening/closing time	0.7 s/0.7 s
Weight	1.5 kg
Size	158 mm x 75.5 mm x 47 mm Rotary Diameter: 84.8mm

### Working Environment

Communication interface	Standard: Modbus RTU (RS485), Digital I/O Optional: TCP/IP, CAN2.0A, PROFINET, EtherCAT * ②
Rated voltage	24 V DC ± 10%
Rated current	1.0 A
Peak current	4.0 A
IP class	IP 40
Recommended environment	0~40°C, under 85% RH
Certification	CE, FCC, RoHS

<input checked="" type="checkbox"/> Built-in Controller	<input checked="" type="checkbox"/> Gripping Force Adjustable	<input checked="" type="checkbox"/> Position Adjustable	<input checked="" type="checkbox"/> Speed Adjustable	<input checked="" type="checkbox"/> Drop Detection	<input checked="" type="checkbox"/> Rotary Adjustable	<input checked="" type="checkbox"/> Self-Locking Mechanism
---	---	---	--	--	---	--

## Technical Drawings

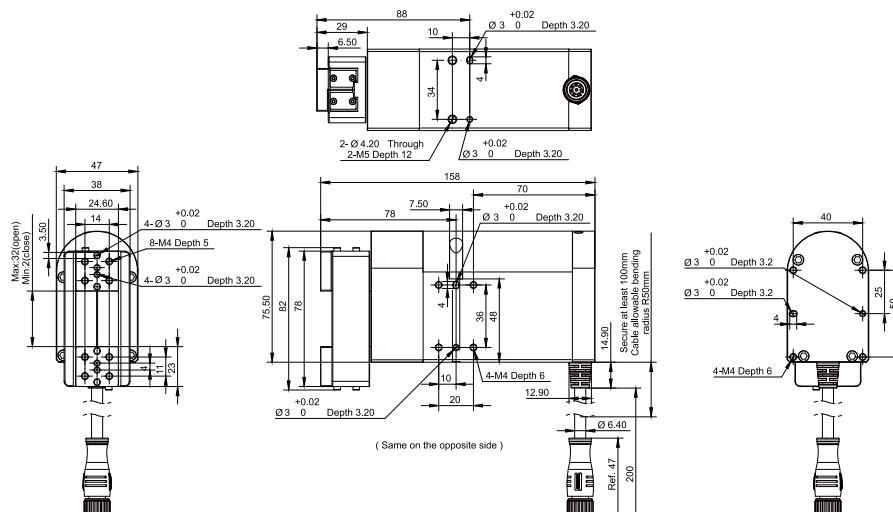

# RGD Series

## Electric Direct Drive Rotary Gripper

RGD-5-14    RGD-35-14  
RGD-5-30    RGD-35-30



The RGD direct-drive electric rotary gripper of DH-Robotics adopts a direct-drive backlash-free rotation module to improve the rotary accuracy, and thus is perfectly suited for high-precision manufacturing applications.



### Installation

1. Front installation: use front screw holes for installation
2. Bottom installation: use bottom screw holes for installation

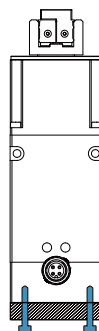
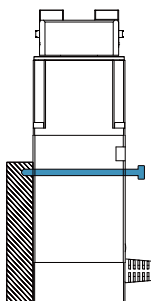

### Product Features

#### ● Zero Rotary Backlash High Repeatability

The RGD series adopts direct-drive rotary motors to realize zero rotary backlash and a rotary resolution of up to 0.01°, which applies to rotary positioning scenarios in semiconductor production.

#### ● High Dynamic Response High-speed Stability

The precision direct-drive technology, coupled with DH-Robotics' excellent drive control, realizes perfect control of gripping and rotation. The rotation speed is up to 1500° per second.

#### ● All-in-one Design Power-off Protection

The gripper adopts the design of integrating the dual servo system of gripping and rotation with the drive control module, which is smaller and more compact, and applies to more scenarios. Brakes are optional to meet the requirements of various applications.



### Application

With the direct-drive technology, the RGD gripper can provide greatly improved rotary accuracy, which can be used in scenarios such as the high-precision positioning assembly, transport, and deflection correction of 3C electronics and semiconductors.



# RGD-5-14

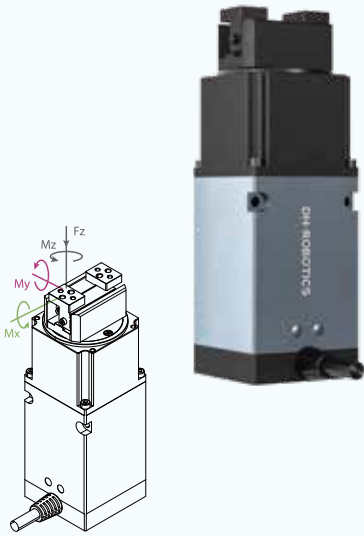

## Static Vertical Allowable Load

**Fz** 150 N

## Allowable Loading Moment

**Mx** 2 N·m

**My** 1.5 N·m

**Mz** 2.5 N·m

① The peak torque can be increased to a maximum of 0.5 N·m. For specific details, please consult with technical support personnel.

② The gripping force on objects depends on factors such as the shape of the object, the material and friction of the contact surface, and the acceleration of movement. The displacement of the center of gravity of the grasped object can also affect the load. If you have any questions, please contact us.

③ When using the optional communication protocol, an external communication box is required. For details, you can consult with our sales representatives.

④ It is recommended to power the device with a power supply that matches the peak current. In cases where the power supply is insufficient, there is a possibility of unintentional triggering of the brake.

## Parameters

### Product Parameter

Gripping force (per jaw)	2-5.5 N
Stroke	14 mm
Rated torque	0.1 N·m
Peak torque	0.25 N·m * <sup>①</sup>
Rotary range	Infinite Rotating
Recommended workpiece weight	0.05 kg * <sup>②</sup>
Max. rotation speed	1500 °/s
Rotary backlash	Zero backlash
Repeat accuracy (swiveling)	± 0.1 °
Repeat accuracy (position)	± 0.02 mm
Opening/closing time	0.5 s/0.5 s
Noise emission	< 60 dB
Weight	0.86 kg(without brake) 0.88 kg(with brake)
Size	149 mm x 50 mm x 50 mm Rotary Diameter:48.7mm

### Working Environment

Communication interface	Modbus RTU (RS485) Optional: TCP/IP, EtherCAT* <sup>③</sup>
Rated voltage	24 V DC ± 10%
Rated current	1.2 A
Peak current	2.5 A* <sup>④</sup>
IP class	IP 40
Recommended environment	0~40°C, under 85% RH

### Certification

CE, FCC, RoHS

● Built-in Controller	● Gripping Force Adjustable	● Position Adjustable	● Speed Adjustable	● Drop Detection	● Rotary Adjustable	● X Self-locking Mechanism
-----------------------	-----------------------------	-----------------------	--------------------	------------------	---------------------	----------------------------

## Technical Drawings

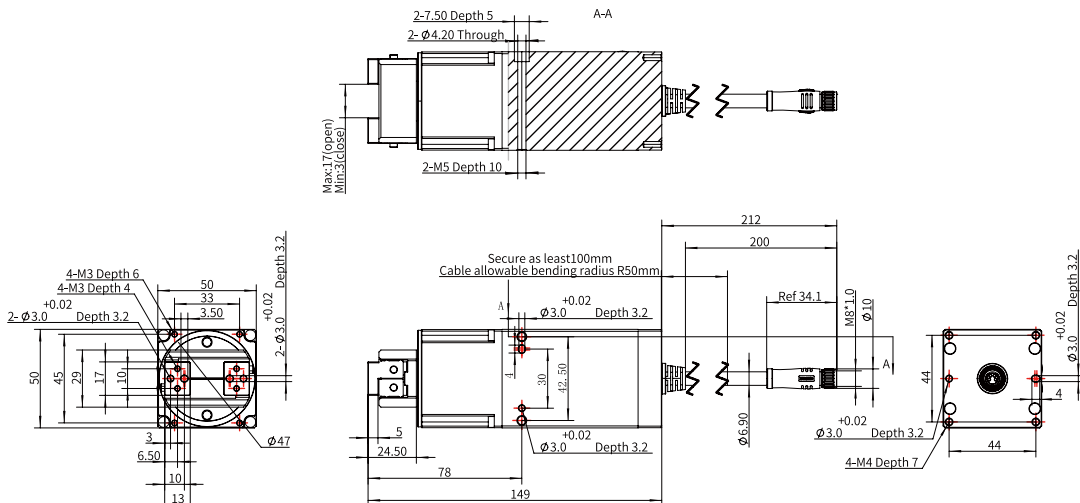

# RGD-5-30



## Static Vertical Allowable Load

**Fz 150 N**

## Allowable Loading Moment

**Mx 2 N·m**

**My 1.5 N·m**

**Mz 2.5 N·m**

① The peak torque can be increased to a maximum of 0.5 N·m. For specific details, please consult with technical support personnel.

② The gripping force on objects depends on factors such as the shape of the object, the material and friction of the contact surface, and the acceleration of movement. The displacement of the center of gravity of the grasped object can also affect the load. If you have any questions, please contact us.

③ When using the optional communication protocol, an external communication box is required. For details, you can consult with our sales representatives.

④ It is recommended to power the device with a power supply that matches the peak current. In cases where the power supply is insufficient, there is a possibility of unintentional triggering of the brake.

## Parameters

### Product Parameter

Gripping force (per jaw)	2-5.5 N
Stroke	30 mm
Rated torque	0.1 N·m
Peak torque	0.25 N·m *①
Rotary range	Infinite Rotating
Recommended workpiece weight	0.05 kg *②
Max. rotation speed	1500 °/s
Rotary backlash	Zero backlash
Repeat accuracy (swiveling)	± 0.1 °
Repeat accuracy (position)	± 0.02 mm
Opening/closing time	0.5 s/0.5 s
Noise emission	< 60 dB
Weight	1 kg(without brake) 1.02 kg(with brake)
Size	149 mm x 50 mm x 50 mm Rotary Diameter:83.6mm

### Working Environment

Communication interface	Modbus RTU (RS485) Optional: TCP/IP, EtherCAT*③
Rated voltage	24 V DC ± 10%
Rated current	1.2 A
Peak current	2.5 A *④
IP class	IP 40
Recommended environment	0~40°C, under 85% RH

### Certification

CE, FCC, RoHS

● Built-in Controller	● Gripping Force Adjustable	● Position Adjustable	● Speed Adjustable	● Drop Detection	● Rotary Adjustable	● Self-locking Mechanism
-----------------------	-----------------------------	-----------------------	--------------------	------------------	---------------------	--------------------------

## Technical Drawings

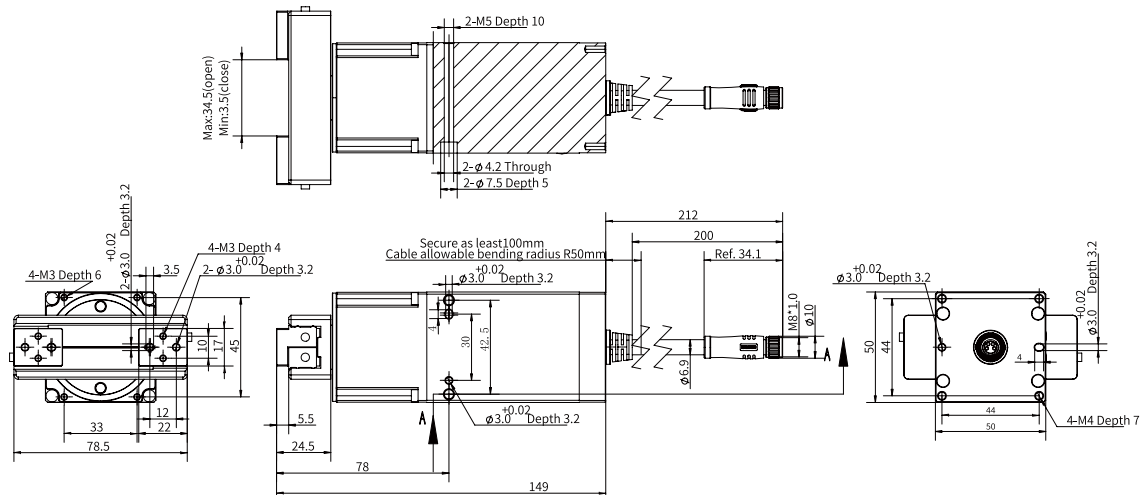

# RGD-35-14

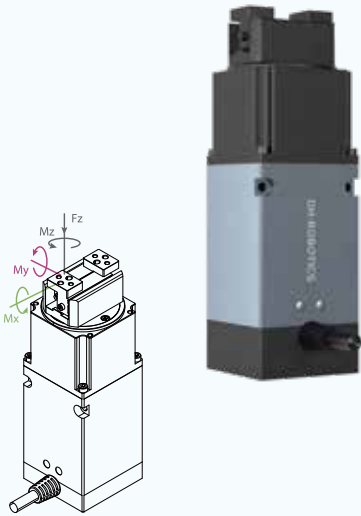

## Static Vertical Allowable Load

**Fz** 150 N

## Allowable Loading Moment

**Mx** 2 N·m

**My** 1.5 N·m

**Mz** 2.5 N·m

① The peak torque can be increased to a maximum of 0.5 N·m. For specific details, please consult with technical support personnel.

② The gripping force on objects depends on factors such as the shape of the object, the material and friction of the contact surface, and the acceleration of movement. The displacement of the center of gravity of the grasped object can also affect the load. If you have any questions, please contact us.

③ When using the optional communication protocol, an external communication box is required. For details, you can consult with our sales representatives.

④ It is recommended to power the device with a power supply that matches the peak current. In cases where the power supply is insufficient, there is a possibility of unintentional triggering of the brake.

## Parameters

### Product Parameter

Gripping force (per jaw)	10-35 N
Stroke	14 mm
Rated torque	0.1 N·m
Peak torque	0.25 N·m <sup>①</sup>
Rotary range	Infinite Rotating
Recommended workpiece weight	0.35 kg <sup>②</sup>
Max. rotation speed	1500 °/s
Rotary backlash	Zero backlash
Repeat accuracy (swiveling)	± 0.1 °
Repeat accuracy (position)	± 0.02 mm
Opening/closing time	0.5 s/0.5 s
Noise emission	< 60 dB
Weight	0.86 kg(without brake) 0.88 kg(with brake)
Size	159 mm x 50 mm x 50 mm Rotary Diameter:48.7mm

### Working Environment

Communication interface	Modbus RTU (RS485) Optional: TCP/IP, EtherCAT <sup>③</sup>
Rated voltage	24 V DC ± 10%
Rated current	1.2 A
Peak current	2.5 A <sup>④</sup>
IP class	IP 40
Recommended environment	0~40°C, under 85% RH

### Certification

CE, FCC, RoHS

<input checked="" type="checkbox"/> Built-in Controller	<input checked="" type="checkbox"/> Gripping Force Adjustable	<input checked="" type="checkbox"/> Position Adjustable	<input checked="" type="checkbox"/> Speed Adjustable	<input checked="" type="checkbox"/> Drop Detection	<input checked="" type="checkbox"/> Rotary Adjustable	<input checked="" type="checkbox"/> Self-locking Mechanism
---	---	---	--	--	---	--

## Technical Drawings

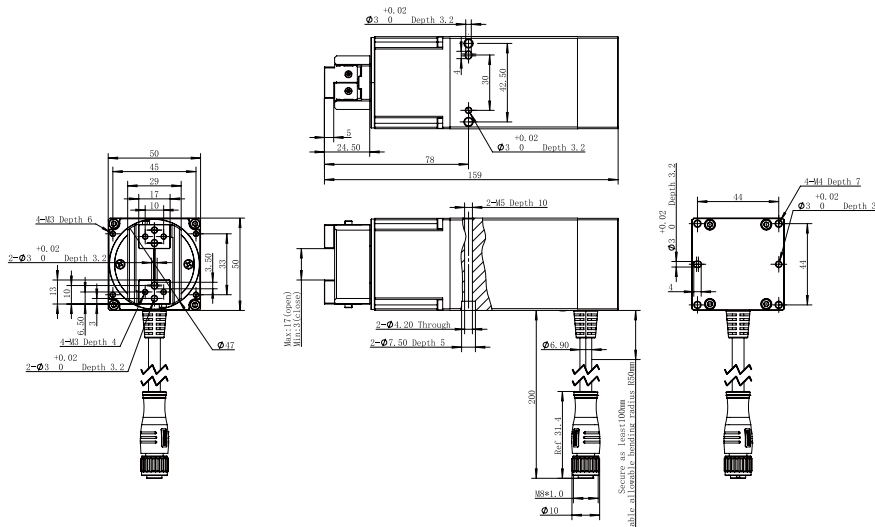



# PGI Series Electric Parallel Gripper

PGI-140-80



Based on the industrial requirements of “long stroke, high load, and high protection level”, DH-Robotics independently developed the PGI series of industrial electric parallel gripper. The PGI series is widely used in various industrial scenarios with positive feedback.

## Installation



1. Front and rear installation: use front and rear screw holes for installation
2. Bottom installation : use bottom screw holes for installation

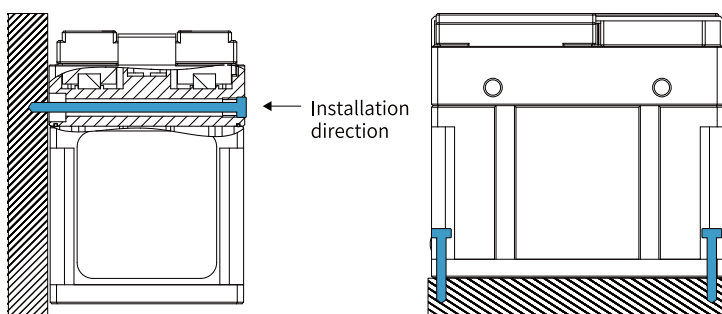

## Product Features

### ● Long Stroke

Long stroke reach to 80 mm. With the customization fingertips, it can stably grasp the medium and large objects below 3kg and suitable for lots of industrial scenes.

### ● High Protection Level

The protection level of PGI-140-80 reaches to IP54, which is able to work under harsh environment with dust and liquid splash.

### ● High Load

The maximum single-sided gripping force of PGI-140-80 is 140 N, and the maximum recommended load is 3 kg, which can meet more diverse gripping needs.

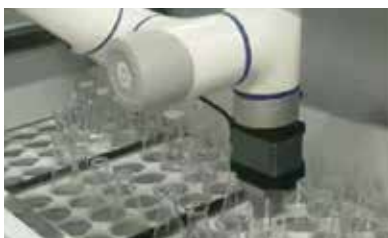
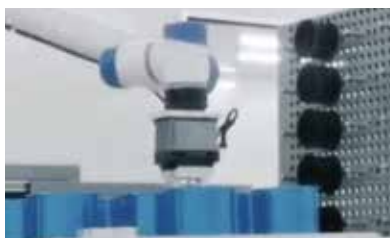

## Application

In industrial scenarios, it is used for gripping, handling and assembly of heavy workpieces. Mostly used in new energy, auto parts, machining, 3C electronics and other industries.

# PGI-140-80

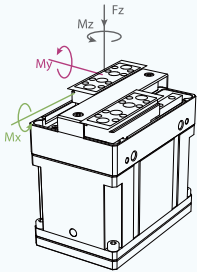

## Static Vertical Allowable Load

**Fz** 300 N

## Allowable Loading Moment

**Mx** 7 N·m

**My** 7 N·m

**Mz** 7 N·m

\*① It depends on the shape of the grasping object, the material and friction of the contact surface, and the acceleration of the motion. If you have any questions, please contact us.

\*② Use optional communication, need external communication conversion box, please consult the sales staff for details

## Parameters

### Product Parameter

Gripping force (per jaw)	40~140 N
Stroke	80 mm
Recommended workpiece weight * ①	3 kg
Opening/closing time	1.1 s/1.1 s
Repeat accuracy (position)	± 0.03 mm
Noise emission	< 50 dB
Weight	1 kg (exclude fingers)
Driving method	Precise planetary gears + Rack and pinion
Size	95 mm x 61.7 mm x 86 mm

### Working Environment

Communication interface	Standard: Modbus RTU (RS485), Digital I/O Optional: TCP/IP, USB2.0, CAN2.0A, PROFINET, EtherCAT *②
Rated voltage	24 V DC ± 10%
Rated current	0.5 A
Peak current	1.2 A
IP class	IP 54
Recommended environment	0~40°C, under 85% RH
Certification	CE, FCC, RoHS

● Built-in Controller	● Gripping Force Adjustable	● Position Adjustable	● Speed Adjustable	● Drop Detection	● Self-locking Mechanism
-----------------------	-----------------------------	-----------------------	--------------------	------------------	--------------------------

## Technical Drawings

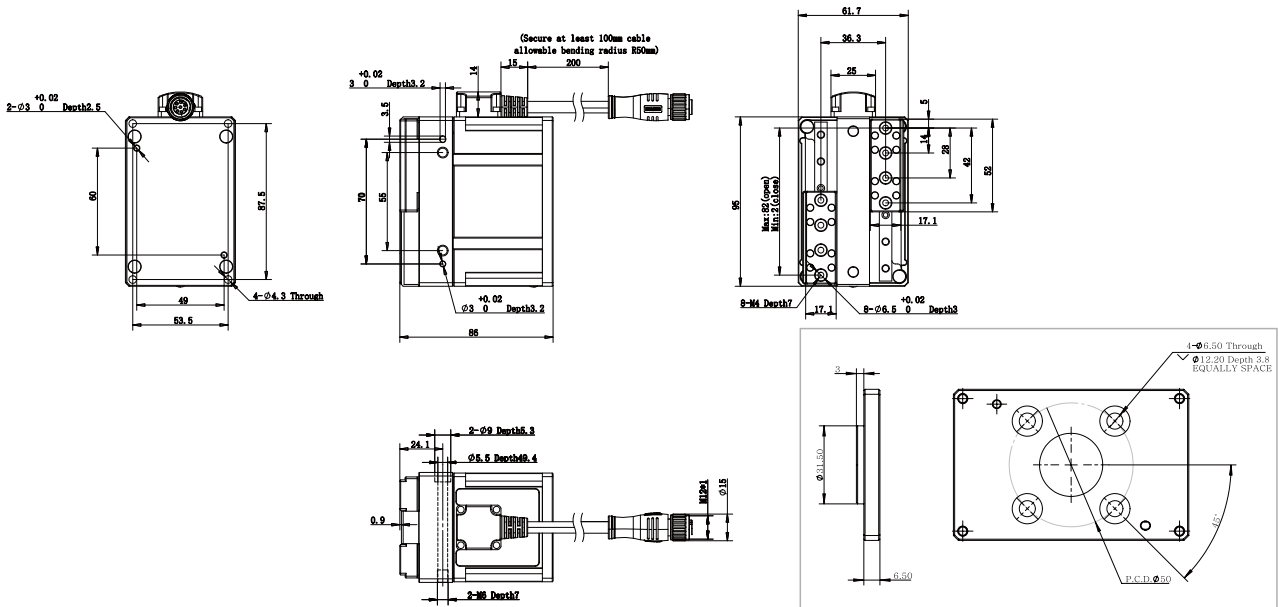

# PGHL Series

## Heavy-Load Long-Stroke Electric Parallel Gripper

PGHL-400-80



PGHL series is an industrial flat electric gripper developed and produced by DH-Robotics. With its compact design, heavy load and high force control accuracy, it can be applied to heavier load clamping requirements and more application scenarios.



### Installation

Bottom installation: use bottom screw holes for installation

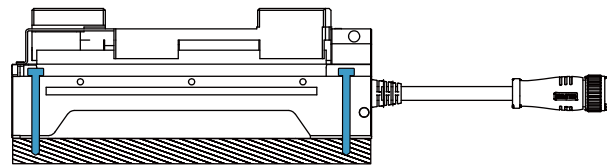
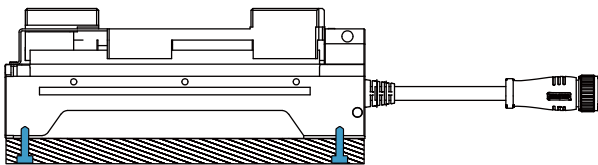

### Product Features

#### ● Flat Electric Gripper High Energy density

PGHL-400-80 industrial flat electric gripper, the structure of which is delicate and meticulous. The length, width and height dimensions is only 194 × 73 × 70mm. This model can provide large clamping force and fast clamping beat, coming with mechanical self-locking mechanism, challenge the limit of large load and thin size.

#### ● High Force Control Accuracy

The force repeatability is  $\pm 40\text{N}(\pm 10\%)$ . Far better than ordinary products in the market by  $\pm 10\% \sim \pm 20\%$  of force control accuracy.

#### ● Quick Response Intelligent planning speed

Opening/closing time up to 1.0s/1.1s, with speed control optimization and mechanical self-locking mechanism function, it can meet fast and stable gripping needs of the production line



### Application

Applied in industrial production of large weight and large volume workpieces gripping and handling, such as lithium batteries in the new energy industry package gripping, large machined parts in automobile assembly production in automotive assembly.



# PGHL-400-80

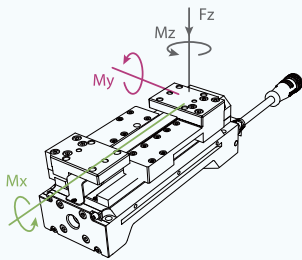

## Static Vertical Allowable Load

**Fz** 1000 N

## Allowable Loading Moment

**Mx** 50 N·m

**My** 50 N·m

**Mz** 15 N·m

\*① It depends on the shape of the grasping object, the material and friction of the contact surface, and the acceleration of the motion, if you have any questions, please contact us.

\*② Use optional communication, need external communication conversion box, please consult the sales staff for details

## Parameters

### Product Parameter

Gripping force (per jaw)	140~400 N
Stroke	80 mm
Recommended workpiece weight *①	8 kg
Opening/closing time	1.0 s/ 1.1 s
Repeat accuracy (position)	± 0.02 mm
Noise emission	< 60 dB
Weight	2.2 kg
Driving method	Precise planetary gears + Tshaped lead screw+ Rack and pinion
Size	194 mm x 73 mm x 70 mm

### Working Environment

Communication interface	Standard: Modbus RTU (RS485), Digital I/O Optional: TCP/IP, USB2.0, CAN2.0A, PROFINET, EtherCAT *②
Rated voltage	DC 24 V ± 10%
Rated current	1.0 A
Peak current	3.0 A
IP class	IP 40
Recommended environment	0~40°C, under 85% RH
Certification	CE、FCC、RoHS

● Built-in Controller	● Gripping Force Adjustable	● Position Adjustable	● Speed Adjustable	● Drop Detection	● Self-locking Mechanism
-----------------------	-----------------------------	-----------------------	--------------------	------------------	--------------------------

## Technical Drawings

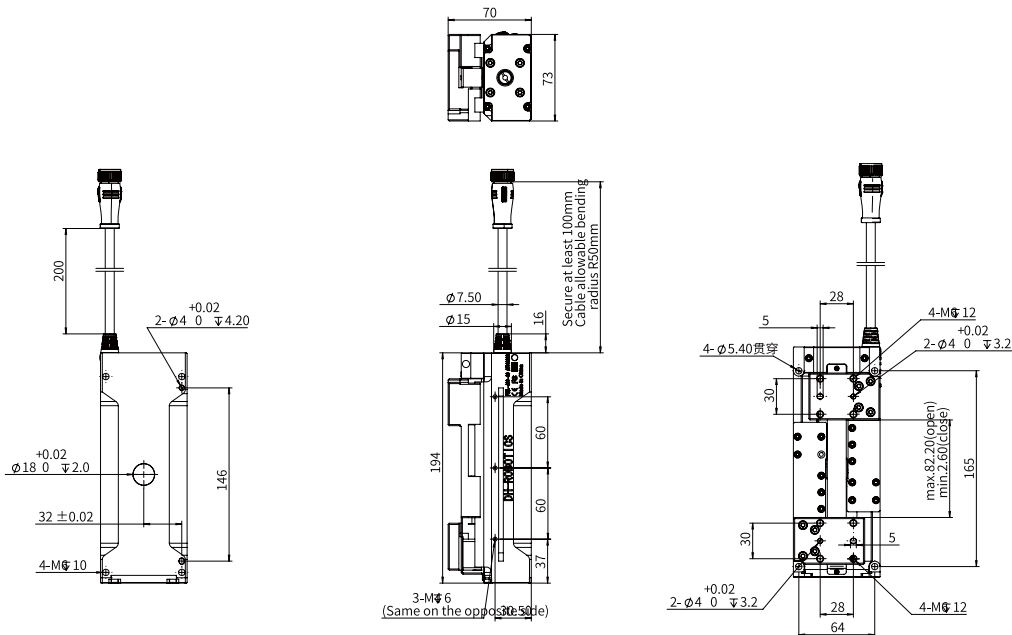

# PGS Series Miniature Electro-magnetic Gripper

PGS-5-5



The PGS series is a miniature electromagnetic gripper with high working frequency. Based on a split design, the PGS series could be applied in space-limited environment with the ultimate compact size and simple configuration.

## Installation



1. Front and rear installation: use front and rear screw holes for installation
2. Bottom installation : use bottom screw holes for installation

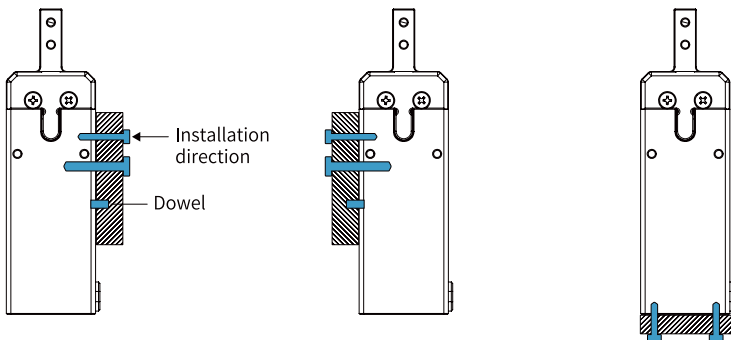

## Product Features

### ● Small Size

Compact size with 20×26 mm, it can be deployed in a relatively small environment.

### ● High Frequency

The opening/closing time could reach 0.03s to meet the needs of fast grasping.

### ● Easy to Use

The configuration is simple with the Digital I/O communication protocol.



## Application

High-frequency fast capture, detection, adjustment and other scenarios in 3C electronics, medical automation, semiconductor and other industries .

# PGS-5-5

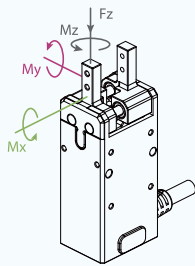

## Static Vertical Allowable Load

**Fz** 150 N

## Allowable Loading Moment

**Mx** 0.62 N·m

**My** 0.62 N·m

**Mz** 0.62 N·m

\*It depends on the shape of the grasping object, the material and friction of the contact surface, and the acceleration of the motion. If you have any questions, please contact us.

## Parameters

### Product Parameter

Gripping force (per jaw)	3.5-5 N
Stroke	5 mm
Recommended workpiece weight *	0.05 kg
Opening/closing time	0.03 s/0.03 s
Repeat accuracy (position)	± 0.01 mm
Noise emission	< 60 dB
Weight	0.2 kg
Driving method	Electromagnet + Spring
Size	Gripper Size: 68.5 mm x 26 mm x 20 mm Controller Size: 67.7 mm x 66.8 mm x 29.6 mm

### Working Environment

Communication interface	Digital I/O
Rated voltage	24 V DC ± 10%
Rated current	0.1 A
Peak current	3.0 A
IP class	IP 40
Recommended environment	0~40°C, under 85% RH
Certification	CE, FCC, RoHS

×	×	×	×	×	●
Built-in Controller	Gripping Force Adjustable	Position Adjustable	Speed Adjustable	Drop Detection	Self-locking Mechanism

## Technical Drawings

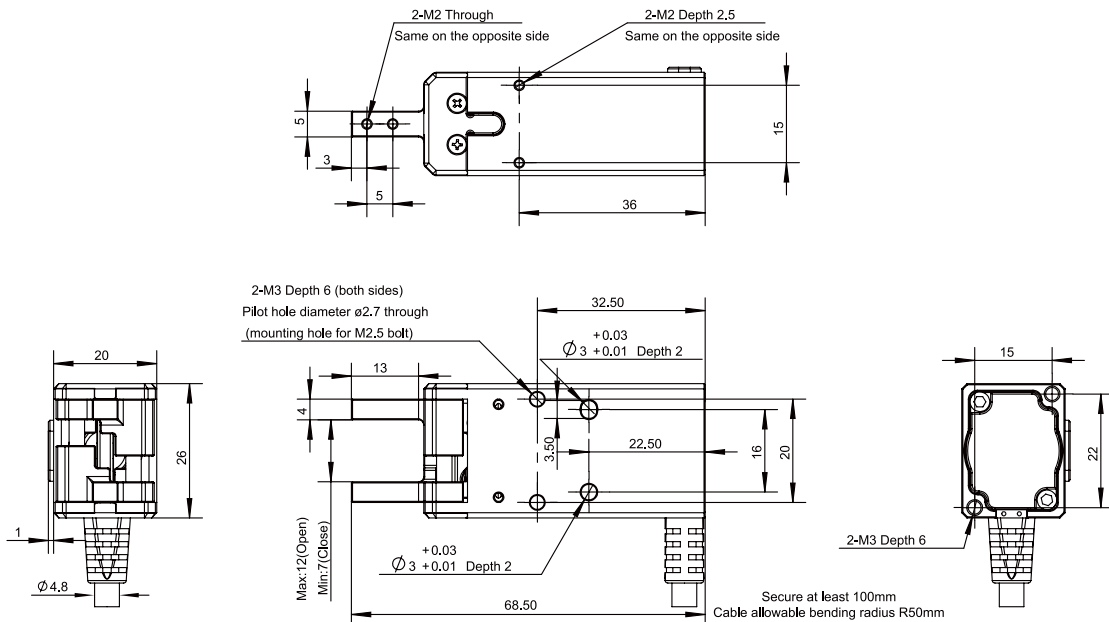

PGE Series  
PGSE Series  
RGI Series  
RGD Series  
PGI Series  
PGHL Series  
PGS Series  
PGC Series  
AG Series  
CG Series

# PGC Series

## Electric Collaborative Parallel Gripper



PGC-50-35  
PGC-140-50  
PGC-300-60

DH-Robotics PGC series of collaborative parallel electric grippers is an electric gripper mainly used in cooperative manipulators. It has the advantages of high protection level, plug and play, large load and so on. The PGC series combines precision force control and industrial aesthetics. In 2021, it won two industrial design awards, the Red Dot Award and the IF Award.



### Installation

1. Bottom installation : use bottom screw holes for installation

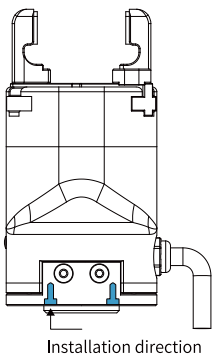

### Product Features

#### ● High protection level

The protection level of PGC series is up to IP67, so the PGC series is able to work under harsh conditions such as machine tending environment.

#### ● Plug & Play

PGC series supports plug & play with most collaborative robot brands on the market which is easier to control and program.

#### ● High Load

The gripping force of the PGC series could reach 300 N, and the maximum load can reach 6 kg, which can meet more diverse gripping needs.



### Application

With collaborative robots, it can complete a series of complex processes including gripping, handling, and assembly in scenarios such as medical automation, 3C electronics, new energy, and new robot retail.

# PGC-50-35

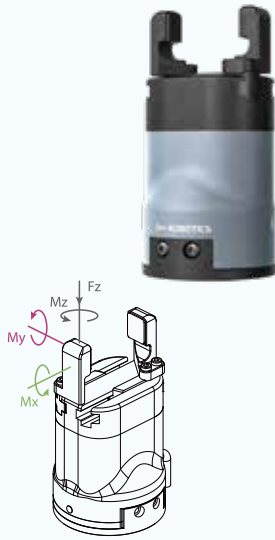

## Static Vertical Allowable Load

**Fz** 150 N

## Allowable Loading Moment

**Mx** 2.5 N·m

**My** 2 N·m

**Mz** 3 N·m

\*① It depends on the shape of the grasping object, the material and friction of the contact surface, and the acceleration of the motion. If you have any questions, please contact us.

\*② Use optional communication, need external communication conversion box, please consult the sales staff for details

## Parameters

### Product Parameter

Gripping force (per jaw)	15~50 N
Stroke	37 mm
Recommended workpiece weight *①	1 kg
Opening/closing time	0.7 s/0.7 s
Repeat accuracy (position)	± 0.03 mm
Noise emission	< 50 dB
Weight	0.5 kg
Driving method	Precise planetary gears + Rack and pinion
Size	124 mm x 63 mm x 63 mm

### Working Environment

Communication interface	Standard: Modbus RTU (RS485), Digital I/O Optional: TCP/IP, USB2.0, CAN2.0A, PROFINET, EtherCAT *②
Rated voltage	24 V DC ± 10%
Rated current	0.25 A
Peak current	0.5 A
IP class	IP 54
Recommended environment	0~40°C, under 85% RH
Certification	CE, FCC, RoHS

●	●	●	●	●	●	×
Built-in Controller	Gripping Force Adjustable	Position Adjustable	Speed Adjustable	Drop Detection	Plug & Play	Self-locking Mechanism

## Technical Drawings

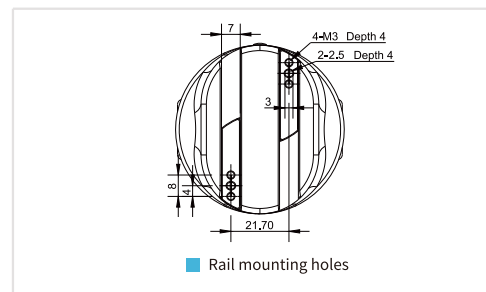
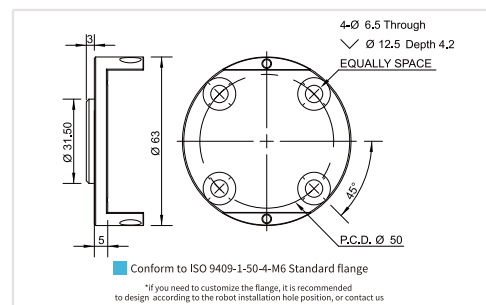
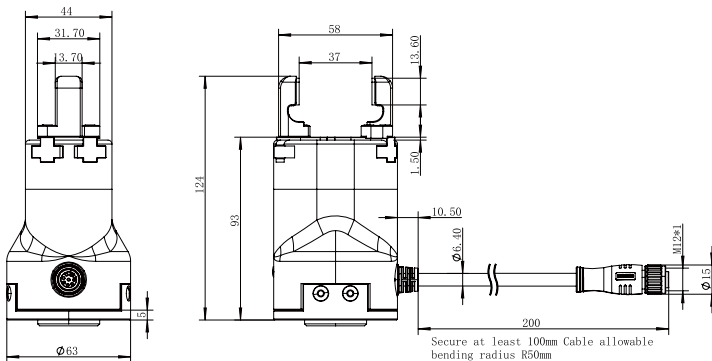

# PGC-140-50

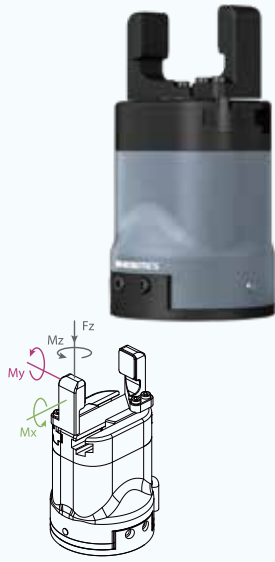

## Static Vertical Allowable Load

**Fz** 300 N

## Allowable Loading Moment

**Mx** 7 N·m

**My** 7 N·m

**Mz** 7 N·m

\*① It depends on the shape of the grasping object, the material and friction of the contact surface, and the acceleration of the motion, if you have any questions, please contact us.

\*② Use optional communication, need external communication conversion box, please consult the sales staff for details

## Parameters

### Product Parameter

Gripping force (per jaw)	40~140 N
Stroke	50 mm
Recommended workpiece weight *①	3 kg
Opening/closing time	0.6 s/0.6 s
Repeat accuracy (position)	± 0.03 mm
Noise emission	< 50 dB
Weight	1 kg
Driving method	Precise planetary gears + Rack and pinion
Size	138.5 mm x 75 mm x 75 mm

### Working Environment

Communication interface	Standard: Modbus RTU (RS485), Digital I/O Optional: TCP/IP, USB2.0, CAN2.0A, PROFINET, EtherCAT *②
Rated voltage	24 V DC ± 10%
Rated current	0.4 A
Peak current	1.0 A
IP class	IP 67
Recommended environment	0~40°C, under 85% RH
Certification	CE, FCC, RoHS

● Built-in Controller	● Gripping Force Adjustable	● Position Adjustable	● Speed Adjustable	● Drop Detection	● Plug & Play	● Self-locking Mechanism
-----------------------	-----------------------------	-----------------------	--------------------	------------------	---------------	--------------------------

## Technical Drawings

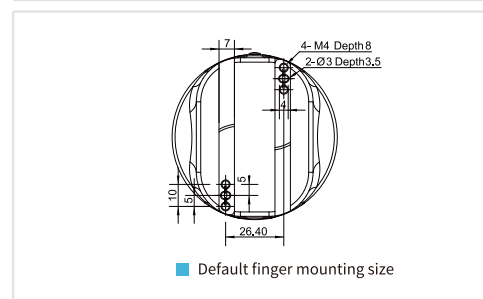
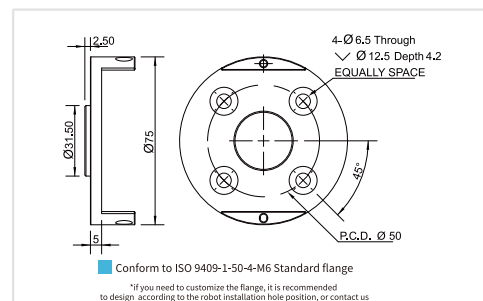
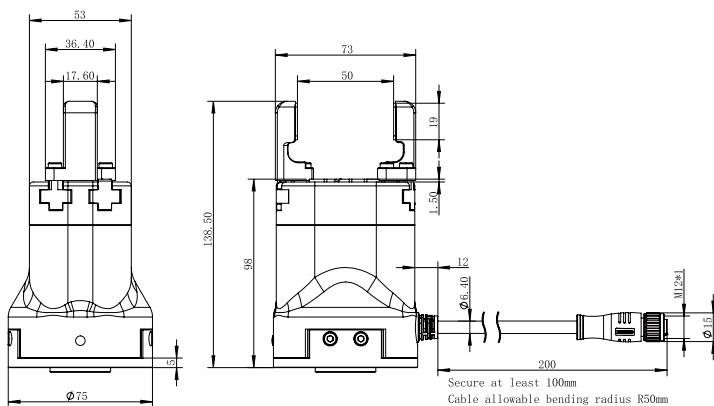

# PGC-300-60

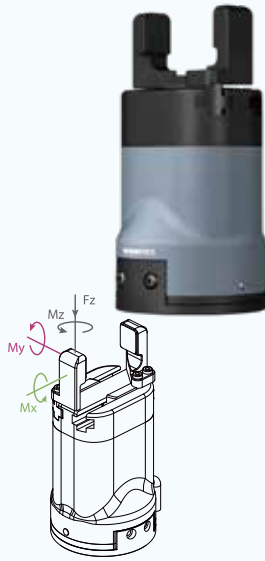

## Static Vertical Allowable Load

**Fz** 600 N

## Allowable Loading Moment

**Mx** 15 N · m

**My** 15 N · m

**Mz** 15 N · m

\*① It depends on the shape of the grasping object, the material and friction of the contact surface, and the acceleration of the motion, if you have any questions, please contact us.

\*② Use optional communication, need external communication conversion box, please consult the sales staff for details

## Parameters

### Product Parameter

Gripping force (per jaw)	80~300 N
Stroke	60 mm
Recommended workpiece weight *①	6 kg
Opening/closing time	0.8 s/0.8 s
Repeat accuracy (position)	± 0.03 mm
Noise emission	< 50 dB
Weight	1.5 kg
Driving method	Precise planetary gears + Rack and pinion
Size	178 mm x 90 mm x 90 mm

### Working Environment

Communication interface	Standard: Modbus RTU (RS485), Digital I/O Optional: TCP/IP, USB2.0, CAN2.0A, PROFINET, EtherCAT *②
Rated voltage	24 V DC ± 10%
Rated current	0.4 A
Peak current	2.0 A
IP class	IP 67
Recommended environment	0~40°C, under 85% RH
Certification	CE, FCC, RoHS

● Built-in Controller	● Gripping Force Adjustable	● Position Adjustable	● Speed Adjustable	● Drop Detection	● Plug & Play	● Self-locking Mechanism
-----------------------	-----------------------------	-----------------------	--------------------	------------------	---------------	--------------------------

## Technical Drawings

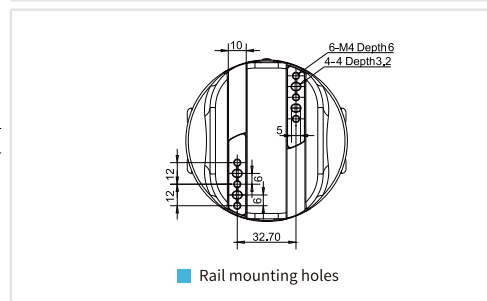
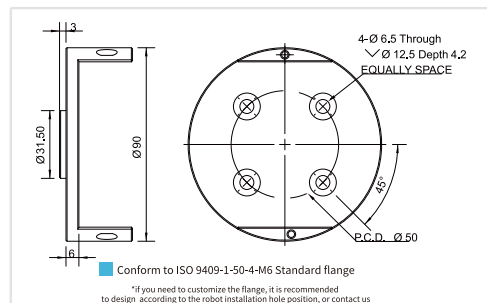
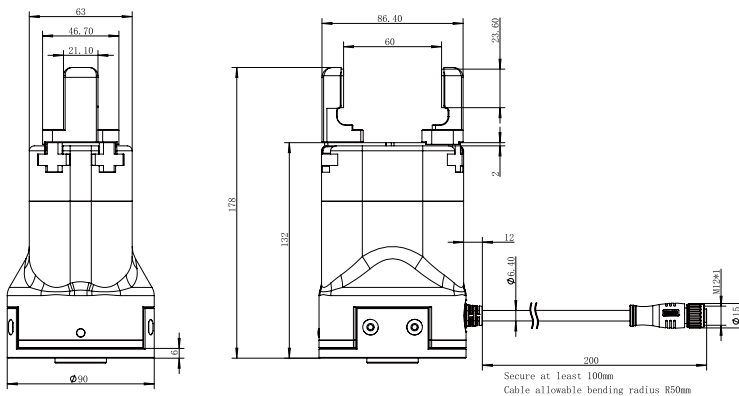



# AG Series Electric Adaptive Gripper



AG-160-95  
AG-105-145  
DH-3

The AG series is a linkage-type adaptive electric gripper which is independently developed by DH-Robotics. With Plug& Play software many and exquisite structural design , AG series is a perfect solution to be applied with collaborative robots to grip work-pieces with different shapes in different industries.



## Installation

1. Bottom installation : use bottom screw holes for installation

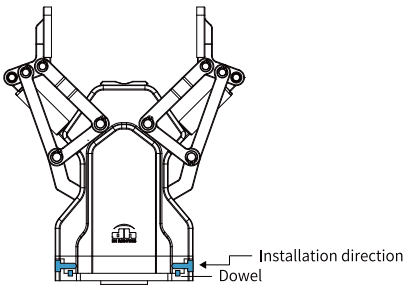

## Product Features

### ● Envelope Adaptive Capture

The gripper linkage mechanism supports envelope adaptive grasping, which is more stable to grip round, spherical or special-shaped objects.

### ● Plug & Play

It supports plug & play with most collaborative robot brands on the market which is easier to control and program.

### ● Long Stroke

The biggest stroke of the AG series is up to 145 mm. One gripper can meet the grasping needs of objects of different sizes with good compatibility.



## Application

Cooperate with collaborative robot or industrial robot to complete material handling, loading and unloading, assembly, testing, sorting and other tasks in auto parts, automation equipment, new energy and other industries.

# AG-160-95

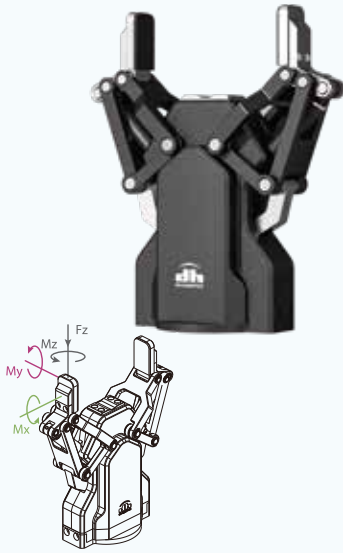

## Static Vertical Allowable Load

Fz 300 N

## Allowable Loading Moment

Mx 4.75 N·m

My 4.75 N·m

Mz 4.75 N·m

\*① It depends on the shape of the grasping object, the material and friction of the contact surface, and the acceleration of the motion. If you have any questions, please contact us.

\*② Use optional communication, need external communication conversion box, please consult the sales staff for details

## Parameters

### Product Parameter

Gripping force (per jaw)	45~160 N
Stroke	95 mm
Recommended workpiece weight * <sup>①</sup>	3 kg
Opening/closing time	0.9 s/0.9 s
Repeat accuracy (position)	± 0.03 mm
Noise emission	< 60 dB
Weight	1 kg
Driving method	Screw drive + Linkage system
Size	184.6 mm x 162.3 mm x 67 mm

### Working Environment

Communication interface	Standard: Modbus RTU (RS485), Digital I/O Optional: TCP/IP, USB2.0, CAN2.0A, PROFINET, EtherCAT * <sup>②</sup>
Rated voltage	24 V DC ± 10%
Rated current	0.8 A
Peak current	1.5 A
IP class	IP 54
Recommended environment	0~40°C, under 85% RH
Certification	CE, FCC, RoHS

● Built-in Controller	● Gripping Force Adjustable	● Position Adjustable	✗ Speed Adjustable	● Drop Detection	● Plug & Play	● Self-Locking Mechanism
-----------------------	-----------------------------	-----------------------	--------------------	------------------	---------------	--------------------------

## Technical Drawings

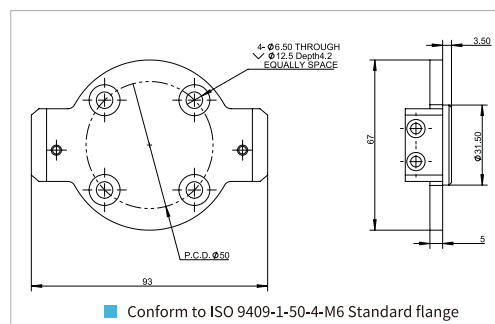
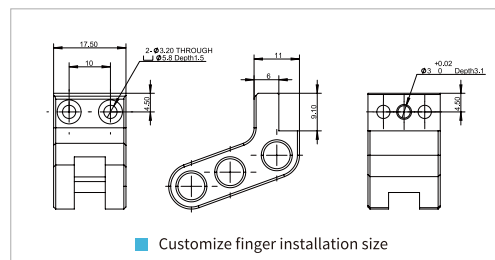
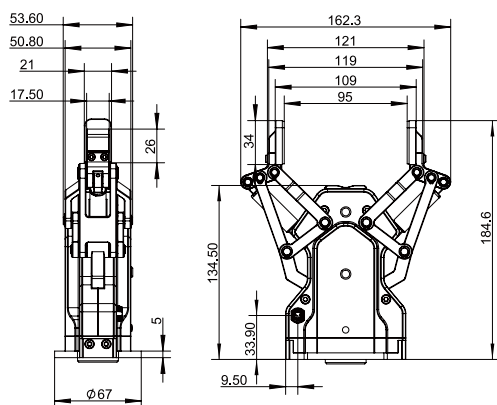



# DH-3

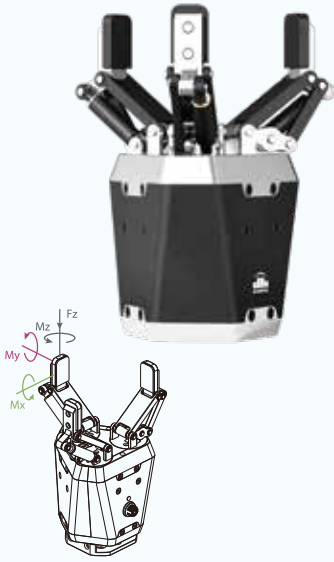

## Static Vertical Allowable Load

Fz 150 N

## Allowable Loading Moment

Mx 2.5 N·m

My 2 N·m

Mz 3 N·m

\*① It depends on the shape of the grasping object, the material and friction of the contact surface, and the acceleration of the motion, if you have any questions, please contact us.

\*② Use optional communication, need external communication conversion box, please consult the sales staff for details

## Parameters

### Product Parameter

Gripping force (per jaw)	10~65 N
Stroke	106 mm (parallel) 122 mm (centric)
Recommended workpiece weight *①	1.8 kg
Opening/closing time	0.7 s/0.7 s
Repeat accuracy (position)	± 0.03 mm
Noise emission	< 60 dB
Weight	1.68 kg
Driving method	Screw nut + gear drive + linkage mechanism
Size	213.5 mm x 170 mm x 118 mm

### Working Environment

Communication interface	Standard: TCP/IP, USB2.0, CAN2.0A Optional: EtherCAT* ②
Rated voltage	24 V DC ± 10%
Rated current	0.5 A
Peak current	1 A
IP class	IP 40
Recommended environment	0~40°C, under 85% RH
Certification	CE, FCC, RoHS

●	●	●	×	×	●	●
Built-in Controller	Gripping Force Adjustable	Position Adjustable	Speed Adjustable	Drop Detection	Plug & Play	Self-locking Mechanism

## Technical Drawings

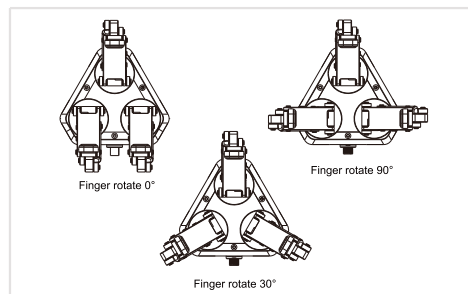
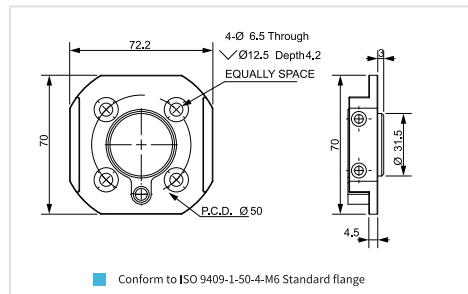
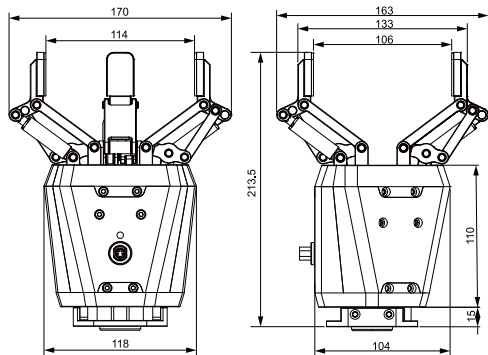

# CG Series Electric Centric Gripper

CGE-10-10

CGI-100-170

CGC-80-10



The CG series is a three-finger centric gripper independently developed by DH-Robotics. The three-finger gripping method can better cope with the grasping task of cylindrical workpieces. The CG series is available in a variety of models for a variety of scenarios, stroke and end devices.



## Installation

1. Front and rear installation: use front and rear screw holes for installation
2. Side installation: use side screw holes for installation
3. Bottom installation : use bottom screw holes for installation

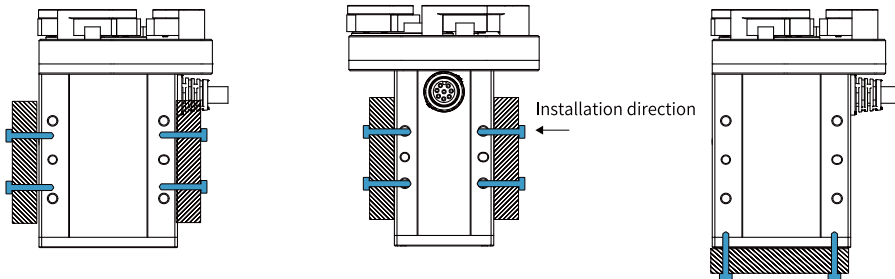

## Product Features

### ● High Performance

Realize high-precision centering and grasping, the process structure meets the requirements of high rigidity, and the energy density exceeds that of similar products

### ● Long Lifetime

Continuous and stable work above 10 millions times without maintenance.

### ● Overload Protection

The high-performance servo motor can provide instantaneous overload protection



## Application

Accurate and stable grasping of cylindrical workpieces in the fields of auto parts, automation equipment, precision machining and assembly, etc.



# CGE-10-10

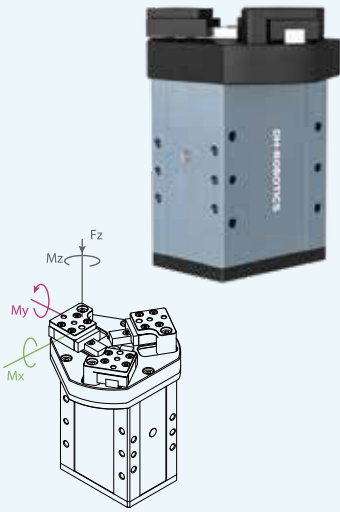

## Static Vertical Allowable Load

**Fz 150 N**

## Allowable Loading Moment

**Mx 0.62 N·m**

**My 0.62 N·m**

**Mz 0.62 N·m**

\*① It depends on the shape of the grasping object, the material and friction of the contact surface, and the acceleration of the motion, if you have any questions, please contact us.

\*② Use optional communication, need external communication conversion box, please consult the sales staff for details

## Parameters

### Product Parameter

Gripping force (per jaw)	3~10 N
Stroke	10 mm
Recommended workpiece weight *①	0.1 kg
Opening/closing time	0.3 s/0.3 s
Repeat accuracy (position)	± 0.03 mm
Noise emission	< 50 dB
Weight	0.43 kg
Driving method	Precise planetary gear reducer + Rack and pinion
Size	94 mm x 53.5 mm x 38 mm

### Working Environment

Communication interface	Standard: Modbus RTU (RS485), Digital I/O Optional: TCP/IP, USB2.0, CAN2.0A, PROFINET, EtherCAT *②
Rated voltage	24 V DC ± 10%
Rated current	0.3 A
Peak current	0.6 A
Recommended environment	0~40°C, under 85% RH
Certification	CE, FCC, RoHS

●	●	●	●	●	×
Built-in Controller	Gripping Force Adjustable	Position Adjustable	Speed Adjustable	Drop Detection	Self-locking Mechanism

## Technical Drawings

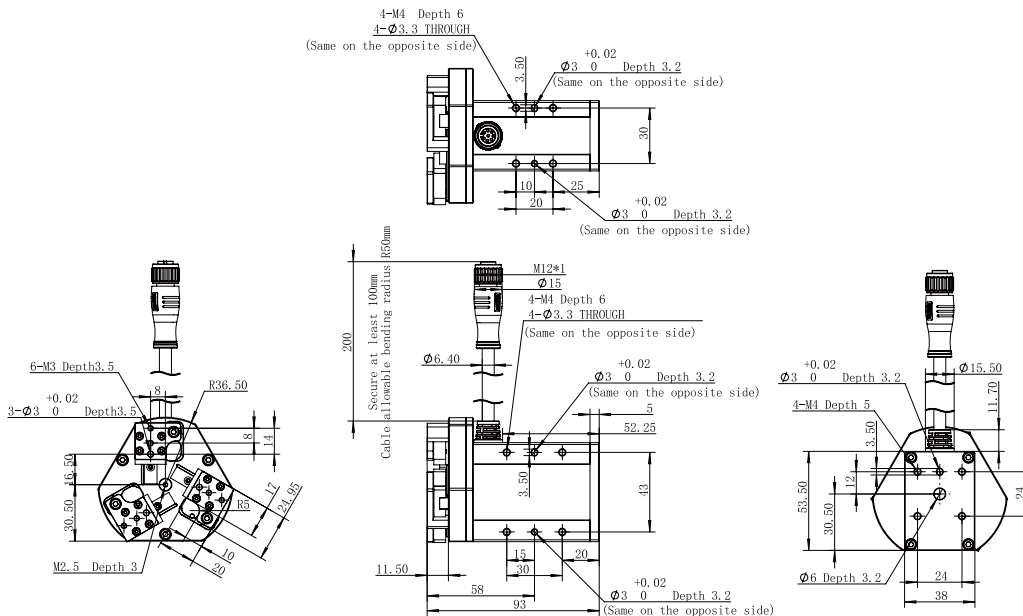

# CGI-100-170

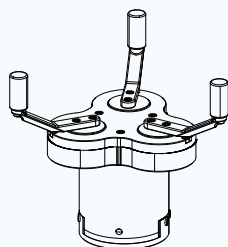

This type of gripper is recommended to use the standard finger. If you need to replace it in the application, please contact us for confirmation.

## Parameters

### Product Parameter

Gripping force (per jaw)	30~100 N
Recommended workpiece diameter (inward)	φ40~φ170 mm
Recommended workpiece weight * <sup>①</sup>	1.5 kg
Opening/closing time	0.5 s/0.5 s
Repeat accuracy (position)	± 0.03 mm
Noise emission	< 50 dB
Weight	1.5 kg
Driving method	Precise planetary gears + Rack and pinion
Size	158.4 mm x 124.35 mm x 116 mm (without brake/with brake, same size)

### Working Environment

Communication interface	Standard: Modbus RTU (RS485), Digital I/O Optional: TCP/IP, USB2.0, CAN2.0A, PROFINET, EtherCAT * <sup>②</sup>
Rated voltage	24 V DC ± 10%
Rated current	0.4 A
Peak current	1 A
IP class	IP 40
Recommended environment	0~40°C, under 85% RH
Certification	CE, FCC, RoHS

\*<sup>①</sup> It depends on the shape of the grasping object, the material and friction of the contact surface, and the acceleration of the motion, if you have any questions, please contact us.

\*<sup>②</sup> Use optional communication, need external communication conversion box, please consult the sales staff for details

●	●	●	●	●	● ×
Built-in Controller	Gripping Force Adjustable	Position Adjustable	Speed Adjustable	Drop Detection	Self-locking Mechanism

## Technical Drawings

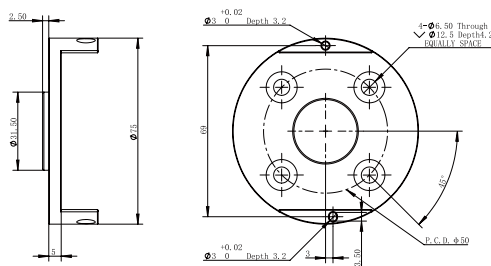
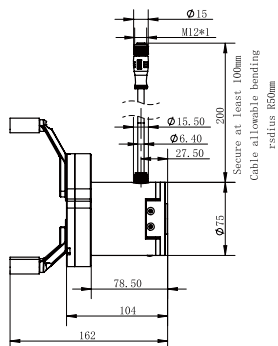
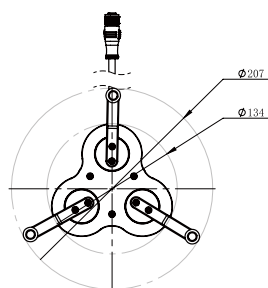
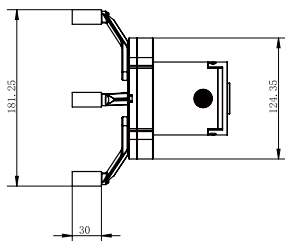

■ Conform to ISO 9409-1-50-4-M6 Standard flange  
\*If you need to customize the flange, it is recommended to design according to the robot installation hole position, or contact us

# CGC-80-10



## Static Vertical Allowable Load

Fz 200 N

## Allowable Loading Moment

Mx 2.5 N·m

My 2 N·m

Mz 3 N·m

\*① It depends on the shape of the grasping object, the material and friction of the contact surface, and the acceleration of the motion, if you have any questions, please contact us.

\*② Use optional communication, need external communication conversion box, please consult the sales staff for details

## Parameters

### Product Parameter

Gripping force (per jaw)	20~80 N
Single jaw	10 mm
Recommended workpiece weight *①	1.5 kg
Opening/closing time	0.2 s/0.2 s
Repeat accuracy (position)	± 0.03 mm
Noise emission	< 50 dB
Weight	1.5 kg
Driving method	Precise planetary gear reducer + Rack and pinion
Size	141 mm x 103 mm x 75 mm

### Working Environment

Communication interface	Standard: Modbus RTU (RS485), Digital I/O Optional: TCP/IP, USB2.0, CAN2.0A, PROFINET, EtherCAT *②
Rated voltage	24 V DC ± 10%
Rated current	0.3 A
Peak current	1 A
IP class	IP 67
Recommended environment	0~40°C, under 85% RH
Certification	CE, FCC, RoHS

● Built-in Controller	● Gripping Force Adjustable	● Position Adjustable	● Speed Adjustable	● Drop Detection	● Plug & Play	● Self-locking Mechanism
-----------------------	-----------------------------	-----------------------	--------------------	------------------	---------------	--------------------------

## Technical Drawings

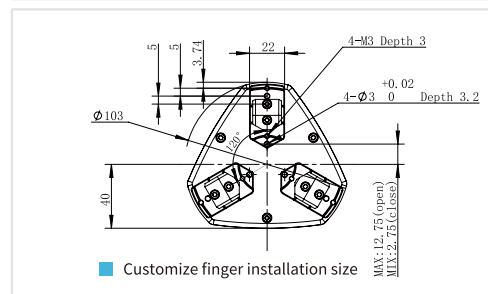
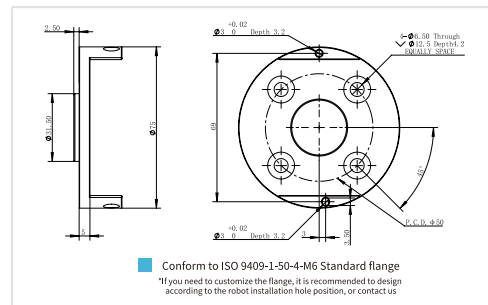
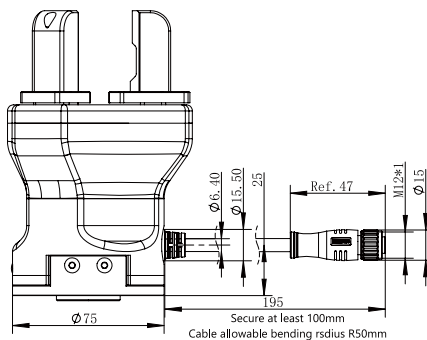
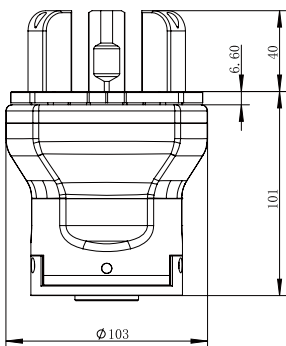

# Honors and Certificates

- Some of Our Certificates

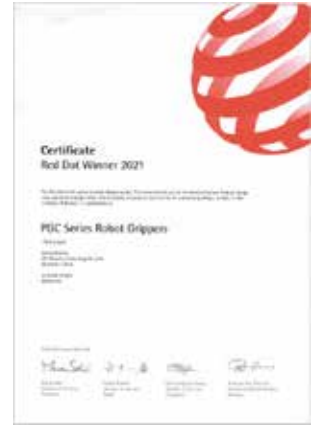

1



2



3



4



5



6



7

1. CE Certificate
2. IP Class Certificate
3. RoHS Certificate
4. EMC Certificate
5. FCC Certificate
6. Low Temperature Test Report
7. Intellectual Property Management System Certification

# Our Customers

More than 800 customers around the world are using DH-Robotics products  
The number of customers continues to grow rapidly...



# Our Eco-Partners

DH-Robotics is a high-quality partner of global collaborative robots

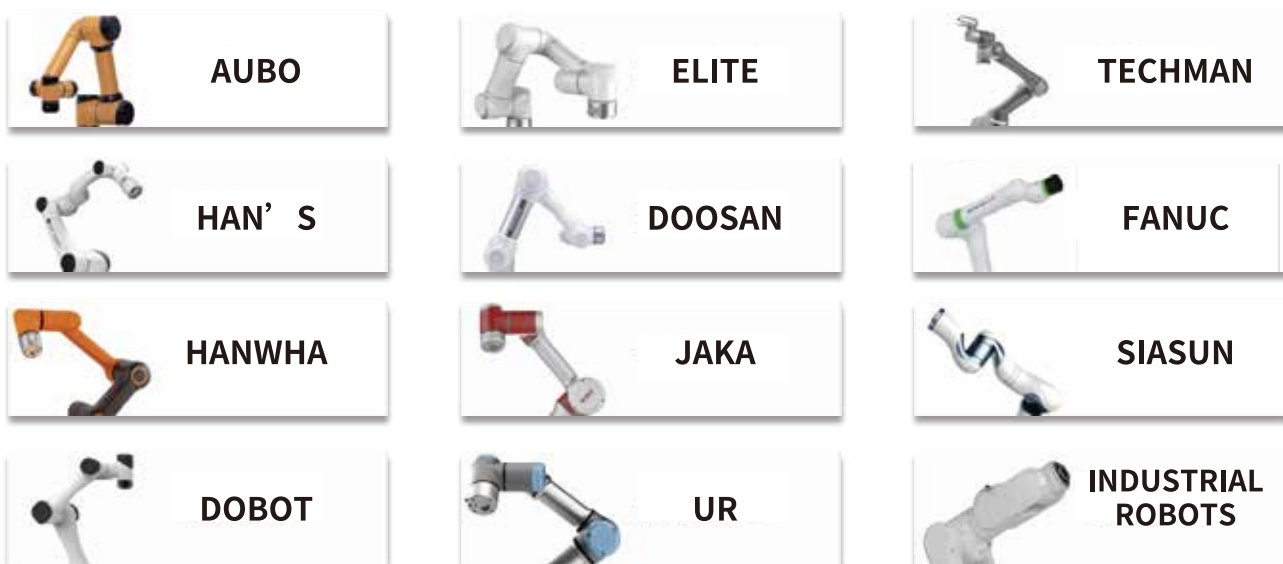



# DH-ROBOTICS

is committed to provide first-class  
core components of precision motion control.







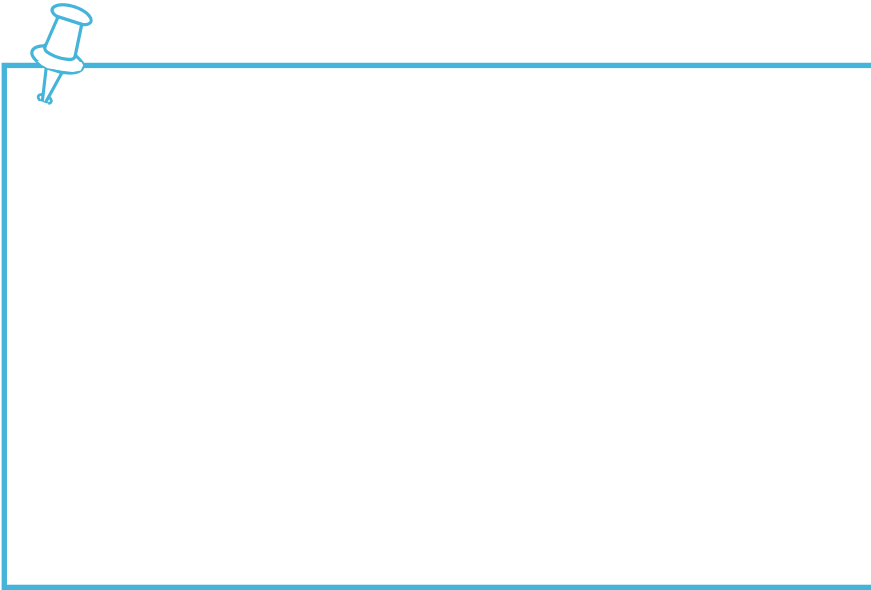

## DH-Robotics Technology Co.,Ltd.

**Linked**  |  **YouTube** [Search DH-Robotics](#)

en.dh-robotics.com  
info@dh-robotics.com

14th Floor, Building A4, Nanshan Intelligence Park, No. 1001 Xueyuan Avenue,  
Taoyuan Street, Nanshan District, Shenzhen City, Guangdong Province, China