



CRA Series

New Generation High Performance
Collaborative Robots

- www.dobot-robots.com
- sales@dobot-robots.com
- [linkedin.com/company/dobot-industry](https://www.linkedin.com/company/dobot-industry)
- [youtube.com/@dobotarm](https://www.youtube.com/@dobotarm)



D20230520

New Generation Collaborative Robots Fully Enhanced Performance

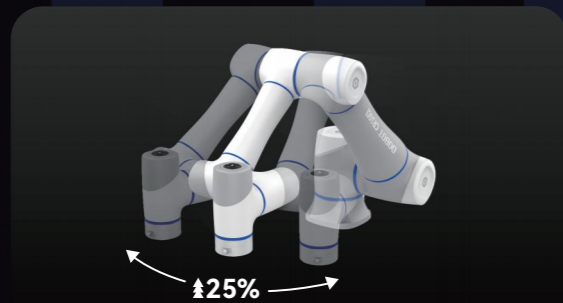

Cycle Time Improved by 25%

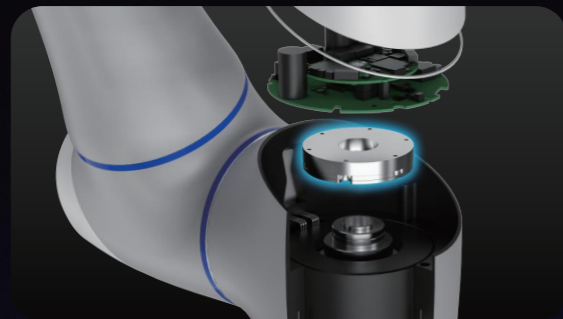

Automatic Brake at Power Outage

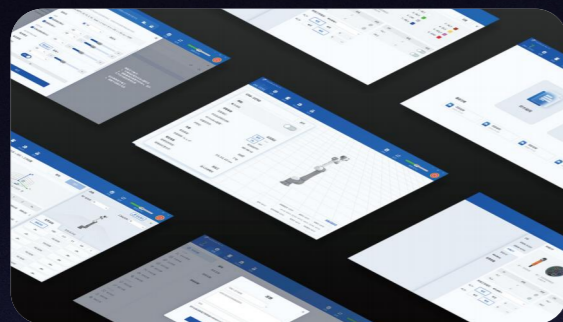

Simplistic UI Design



24-way PNP/NPN
General Purpose I/O Ports



IP54 Dust & Water Resistance



Dual CPU for Better Safety

CONTENTS



Contents

Why Cobots	01 - 02
Key Features	03 - 04
CRA Series	05 - 12
CRAS Series	13 - 14
CRV500	15 - 16
Ecosystem	17 - 18
Solutions	19 - 20
Application Scenarios	21 - 22

Why Cobots



Why Collaborative Robots?

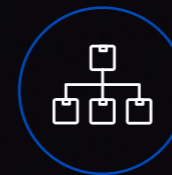

Quick Deployment

Compact, lightweight and supports upright and inverted installation.



Simple Operation

Simple coding allows quick adjustments to be made easily, satisfying the needs for small batch and flexible production.



Safe Collaboration

Multiple protection features including machine halt before collision and at power outage to work safely with workers without the need for safety fences.



Cost Reduction

Plug-and-play ecosystem accessories and solutions can greatly lower the cost for automation transformation.



Improved Efficiency

Workers collaborating with high performance cobots can more than double their productivity.



Consistent Quality

Cobots are highly reliable and perform repetitive tasks at high accuracy to deliver consistent production quality.

Key Features

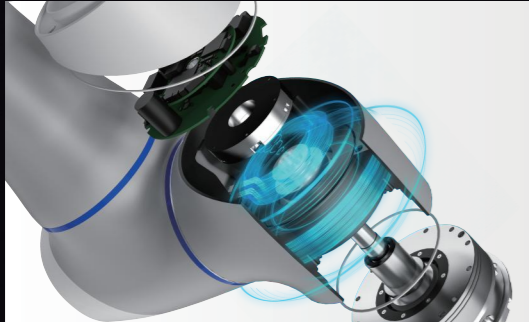

Fast & Efficient

- High performance harmonic drive reducers with high load capacity.
- Highly integrated motor, drive reducer and encoder.
- Modular design allows quick disassembly for easy maintenance.

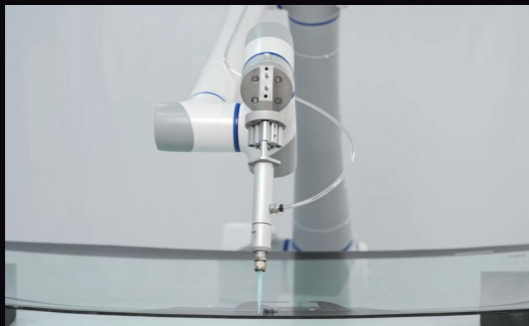

Accurate & Reliable

- By using the micron-level anti-vibration technology, the robot can stop quickly and stably under high speed operation.
- Optimized DH parameters compensation allows for spot on positioning accuracy.
- TrueMotion function ensures trajectory accuracy during complex curved operations.



Safe for Collaboration

- Dual CPUs monitor the status of robot's position, speed and safety I/O and more.
- Collision detection, SafeSkin and virtual boundaries provide multiple layers of safety.
- The CRA series has 22 safety features built-in and is ISO13849 and TS15066 certified.

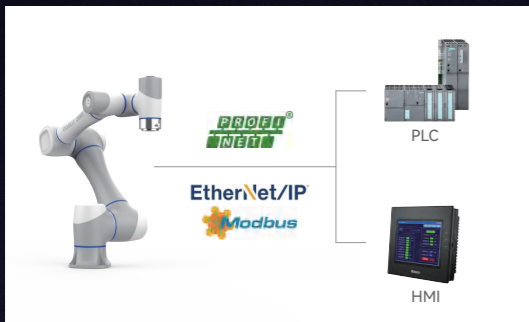

Expandable

- Integrated EtherCAT for reliable real-time microsecond response.
- Supports Modbus, Ethernet/IP and Profinet communication.
- Connects seamlessly with industrial automation systems including the PC, PLC, HMI and more.

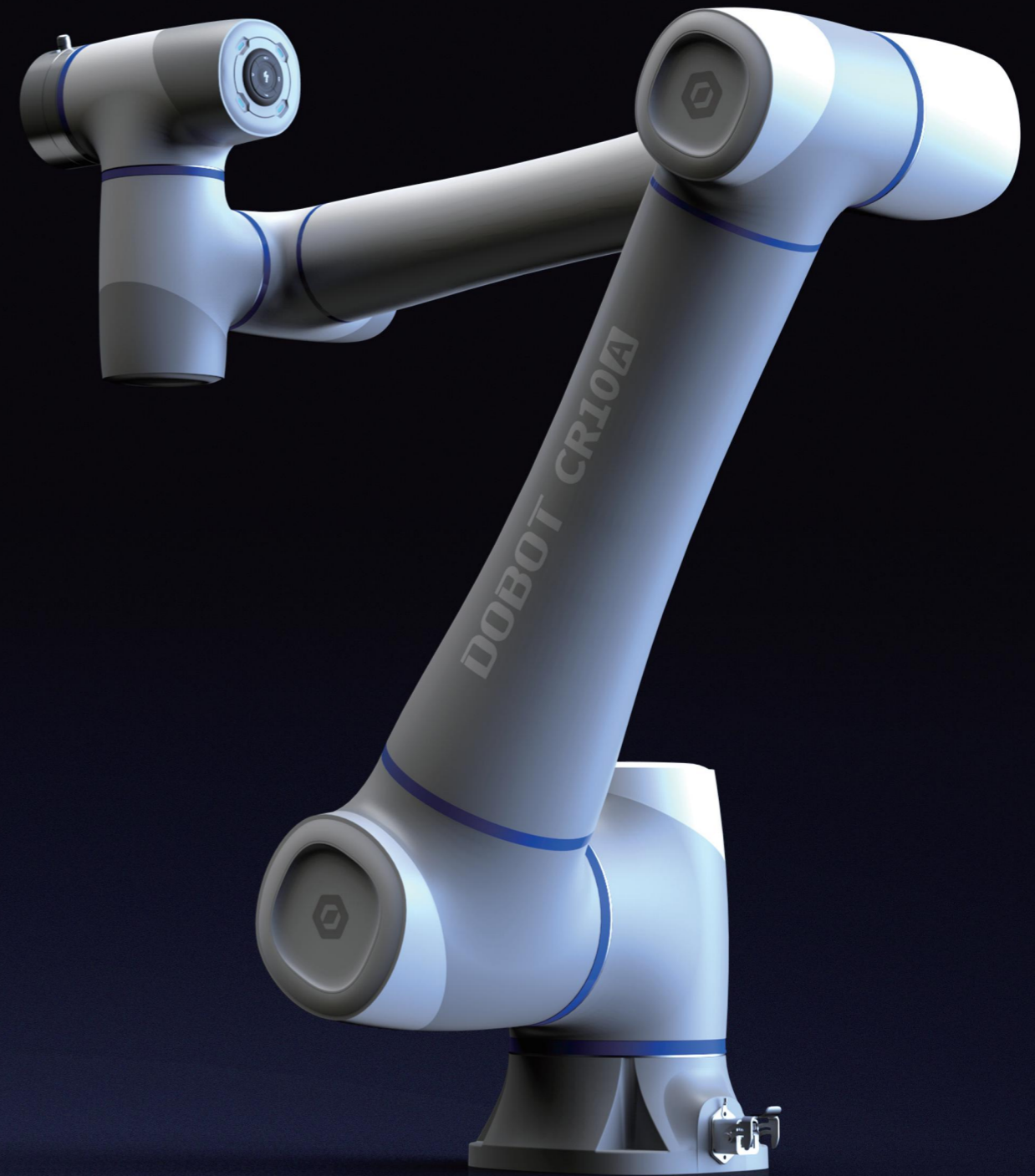

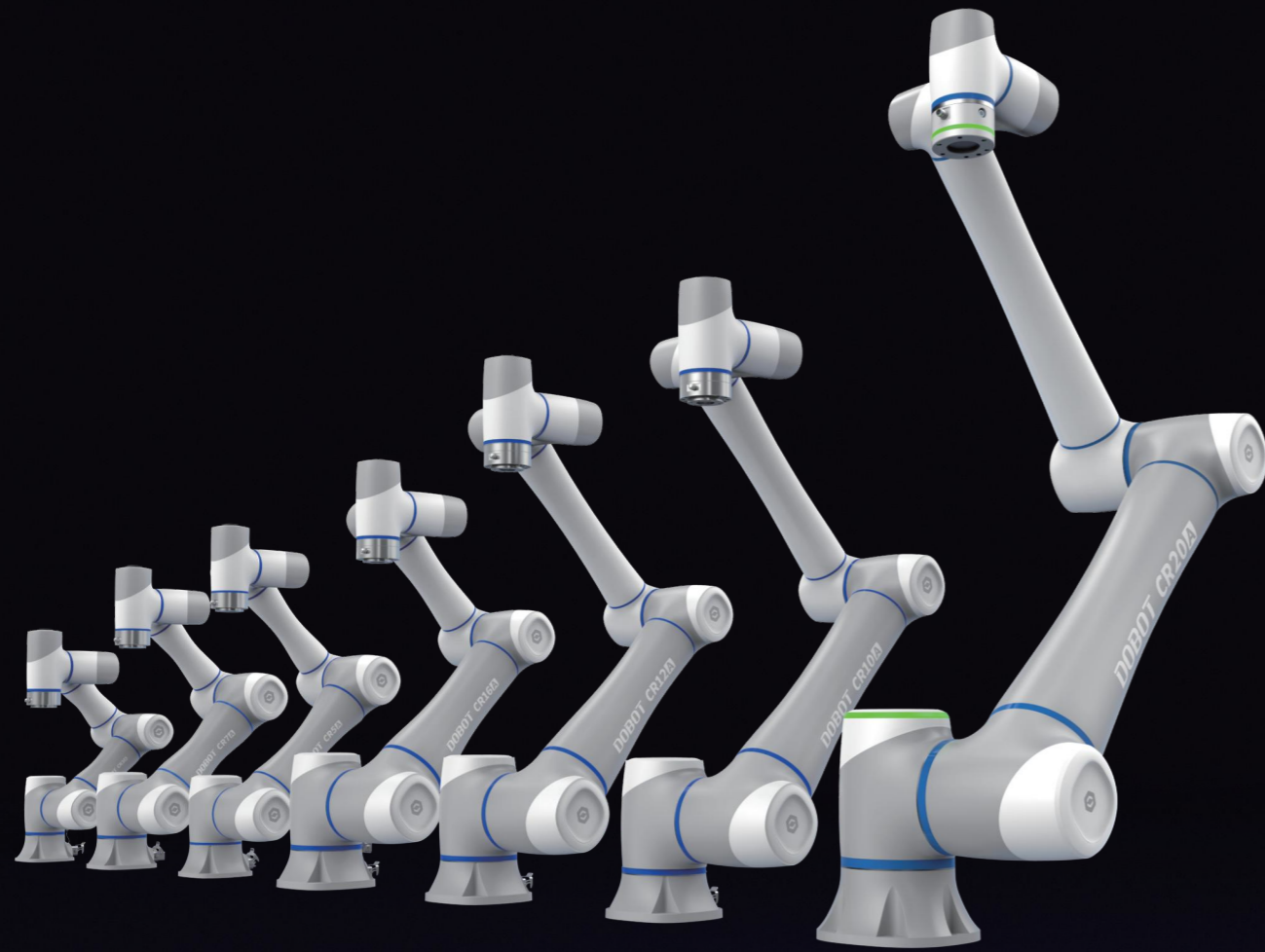

CRA Series

Highly Adaptive & Flexible Productivity

The CRA series is a new generation of high-performance collaborative robots developed by Dobot. It has improved safety, stability, and scalability thanks to the brand new controller and system software and is much easier to operate. It satisfies the performance required by industrial clients, including speed, accuracy and reliability, allowing more efficient human-machine collaboration in industrial scenarios.

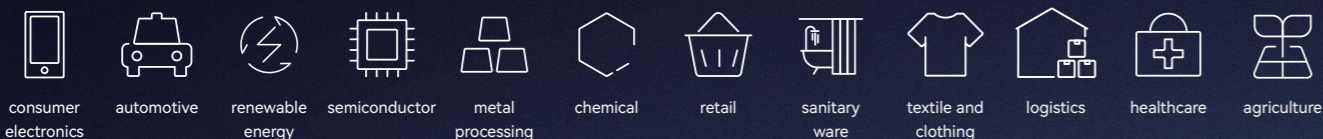

Easy Operation

Intuitive graphical user interface with in-built automation simulation. Control robots with PC, tablets, smartphones, teaching pendant and more. Graphical and script programming are available to accommodate users of diverse background.



Multiple Layers of Protection for Collaboration

The robot has 5 levels of adjustable collision detection settings to meet the safety requirements of different application scenarios. Built-in virtual boundaries to setup operating space. Supports robot halt and deceleration to ensure the safety of nearby workers. With 10-way safety I/O ports, it can meet the needs of most safety control requirements with external devices.

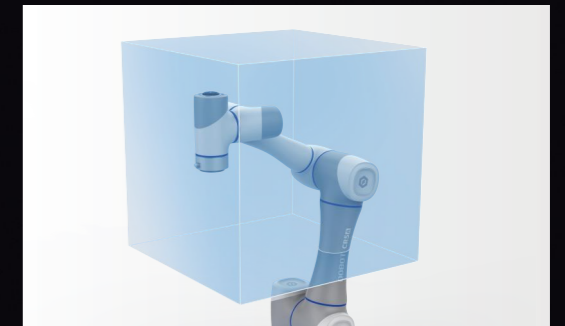

2.5D Vision for Accurate Positioning

Self-developed 2.5D vision positioning feature means that even slanted objects can be picked up accurately. Graphical programming allows users to build solutions quickly. Supports 2D vision feature expansion such as positioning, measurement, detection, and identification.



Electromagnetic Brake Ensures the Safety of Workers and Products

Brakes are auto-engaged 18 ms upon power outage, preventing robotic arms to fall more than 1 mm. No displacement in the case of sudden stops, power on and off.

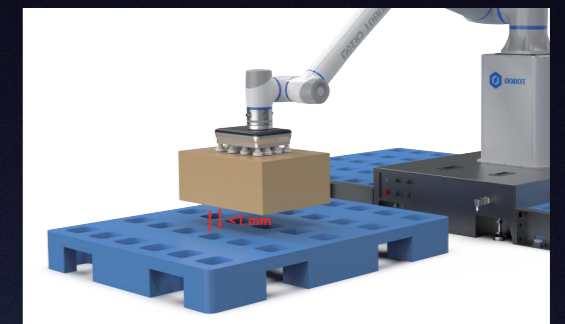

CRA Series Specifications

Model	CR3A	CR5A	CR7A	CR10A	CR12A	CR16A	CR20A	
Weight	16.5 kg	25 kg	24.5 kg	40 kg	39.5 kg	40 kg	70 kg	
Payload	3 kg	5 kg	7 kg	10 kg	12 kg	16 kg	20 kg	
Working Radius	620 mm	900 mm	800 mm	1300 mm	1200 mm	1000 mm	1700 mm	
Maximum Speed of TCP	2 m/s	2 m/s	2 m/s	2 m/s	2 m/s	2 m/s	2 m/s	
Range of Motion	J1/J2	± 360°	± 360°	± 360°	± 360°	± 360°	± 360°	
	J3	± 155°	± 160°	± 160°	± 160°	± 160°	± 165°	
	J4/J5/J6	± 360°	± 360°	± 360°	± 360°	± 360°	± 360°	
Maximum Joint Speed	J1/J2	180° /s	180° /s	180° /s	150° /s	150° /s	120° /s	
	J3	223° /s	180° /s	180° /s	180° /s	180° /s	150° /s	
	J4/J5/J6	223° /s	223° /s	223° /s	223° /s	223° /s	180° /s	
End-Effector I/O Interface	DI/DO/AI	2						4
	RS485	Supported						
Repeatability	± 0.02 mm	± 0.02 mm	± 0.02 mm	± 0.03 mm	± 0.03 mm	± 0.03 mm	± 0.1 mm	
IP Rating	IP54							
Noise	70dB(A)							
Temperature Range	0°C ~ 50°C							
Power Consumption	120W	150W	150W	350W	350W	350W	500W	
Installation Method	Any							
Cable length from main body to control box	5 m						6 m	
Materials	Aluminum alloy, ABS plastic							

CRA Series Control Box Specifications

Product Name	CC262	CC263
Control Box Dimensions	345 mm x 345 mm x 145 mm	400 mm x 400 mm x 175 mm
Weight	AC Version	9.5 kg
	DC Version	8.5 kg
Input Power	AC Version	100 ~ 240V, 47 ~ 63Hz
	DC Version	30 ~ 60V
I/O Power	24V, Max 3A, Maximum 0.5A for one way	
I/O Ports	DI/DO	24 Way (NPN/PNP)
	AI/AO	2 Way, 0 ~ 10V, 4 ~ 20mA
Remote On/Off	Supported	
Communication	WAN	2, for TCP/IP, Modbus TCP, Ethernet/IP communication
	USB	2, for document import and export
	485 Port	1, for RS485, Modbus RTU communication
	Encoder	1, for ABZ incremental encoder
Environments	Temperature	0 ~ 50°C
	Humidity	≤ 95%, Non-condensing
IP Rating	IP20 (IP54 available upon choice)	
Cooling Method	Fan cooling	
Teaching Method	PC, App (Android/ iOS), teaching pendant	
Compatible Models	CR3A ~ CR16A	CR20A

Device Dimensions



CR3A

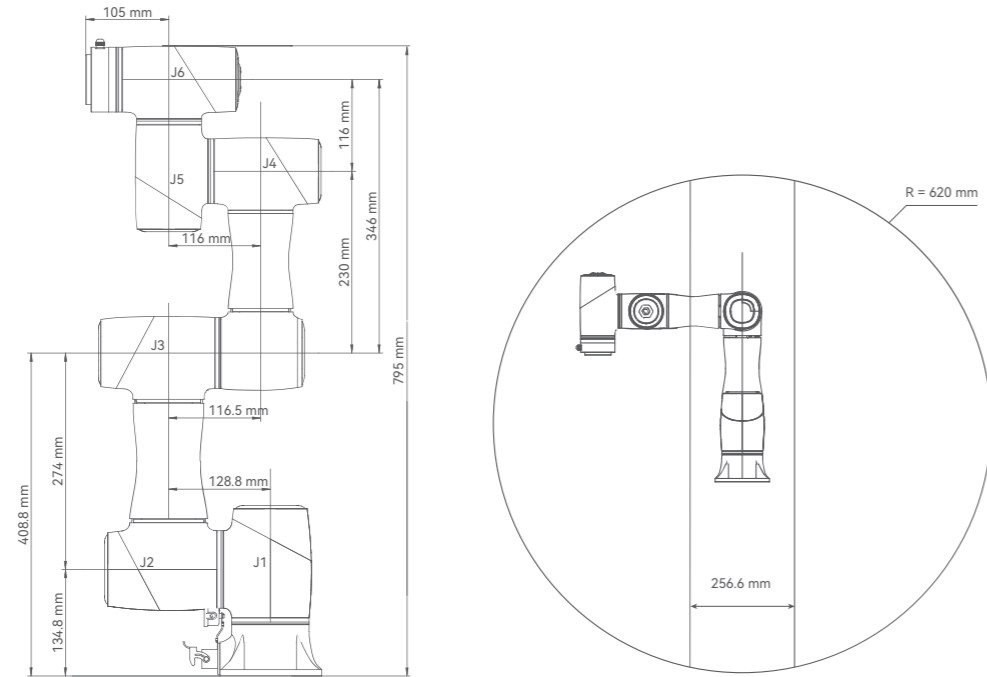

CR7A

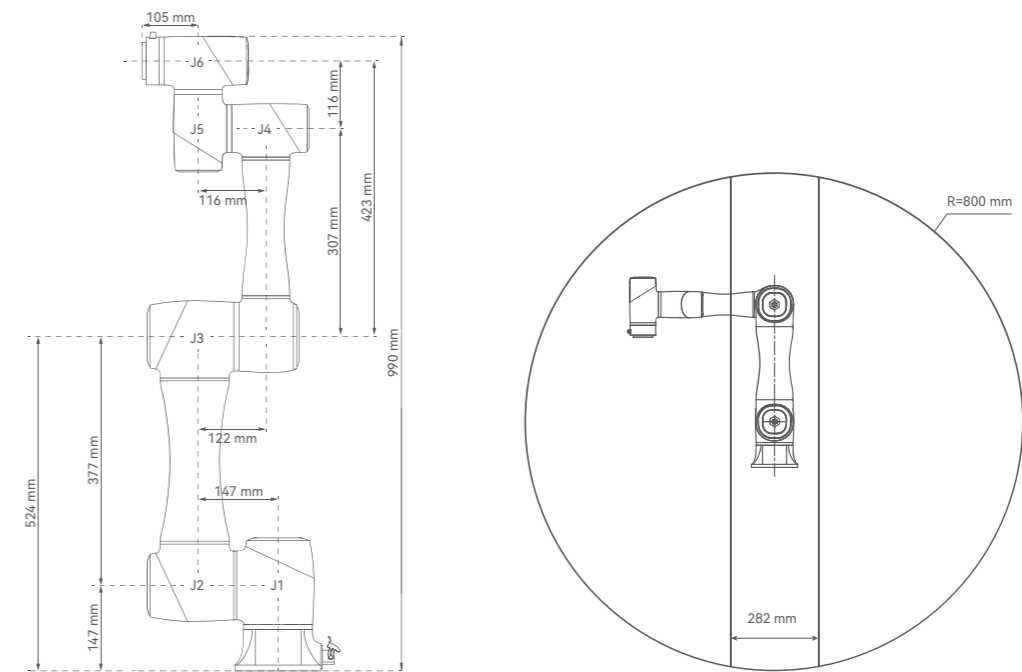

CR5A

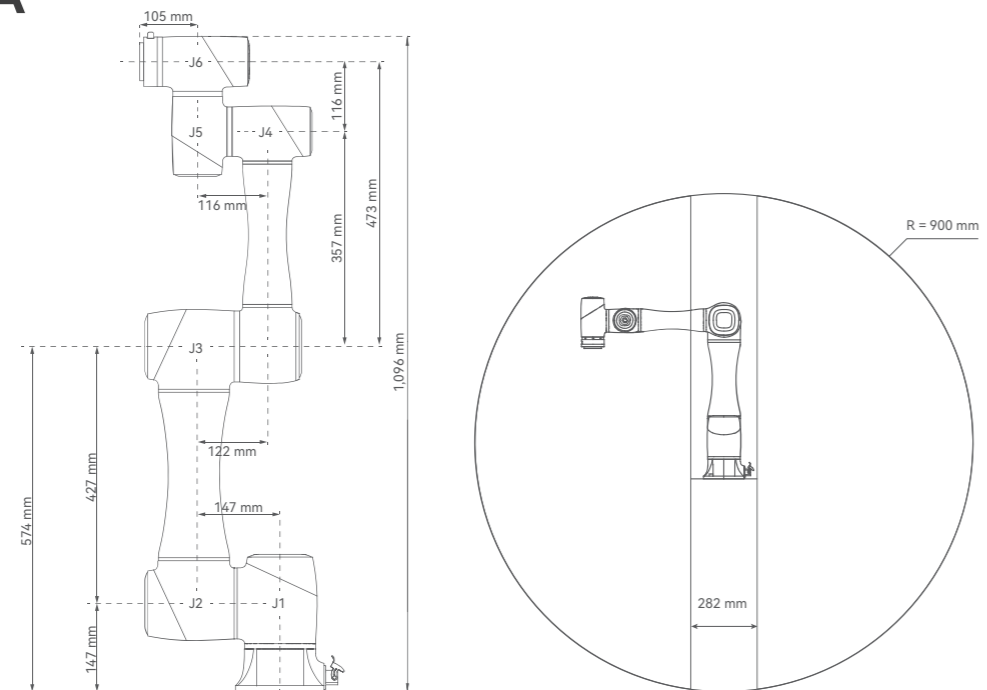

CR10A

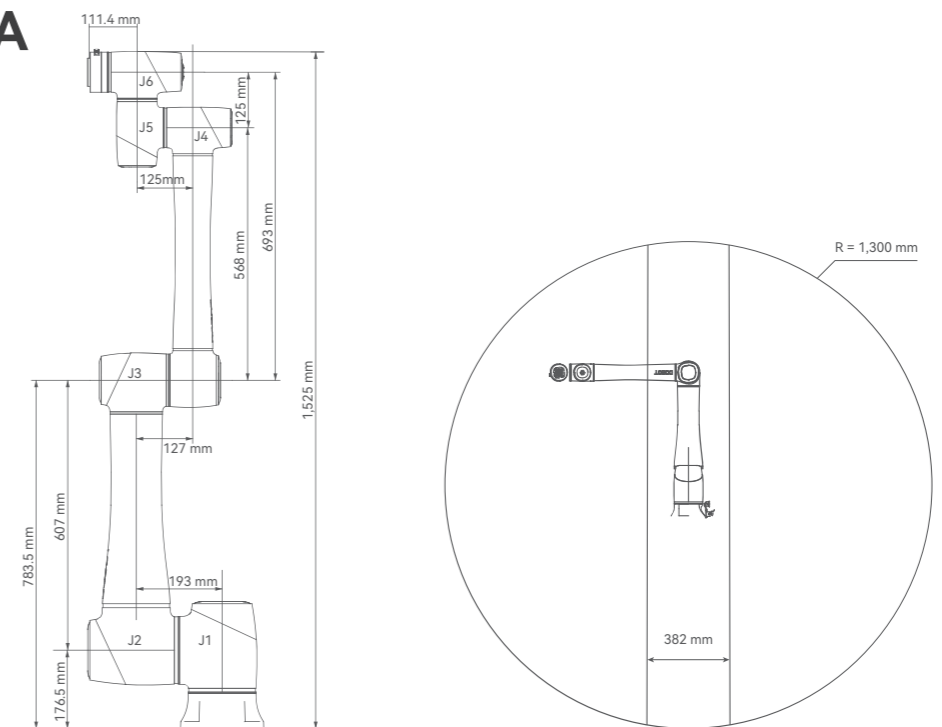

Device Dimensions



CR12A

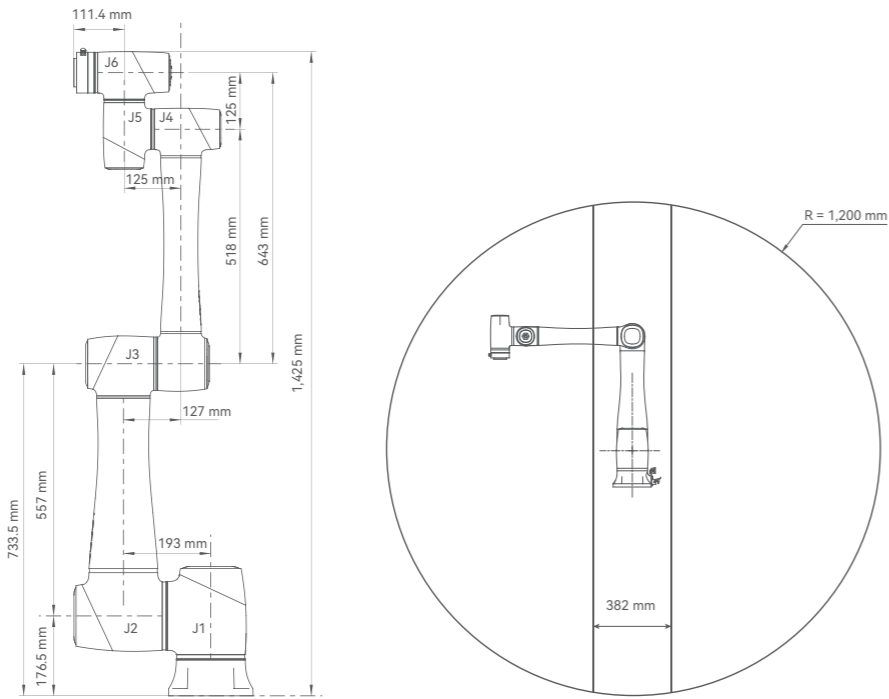

CR20A

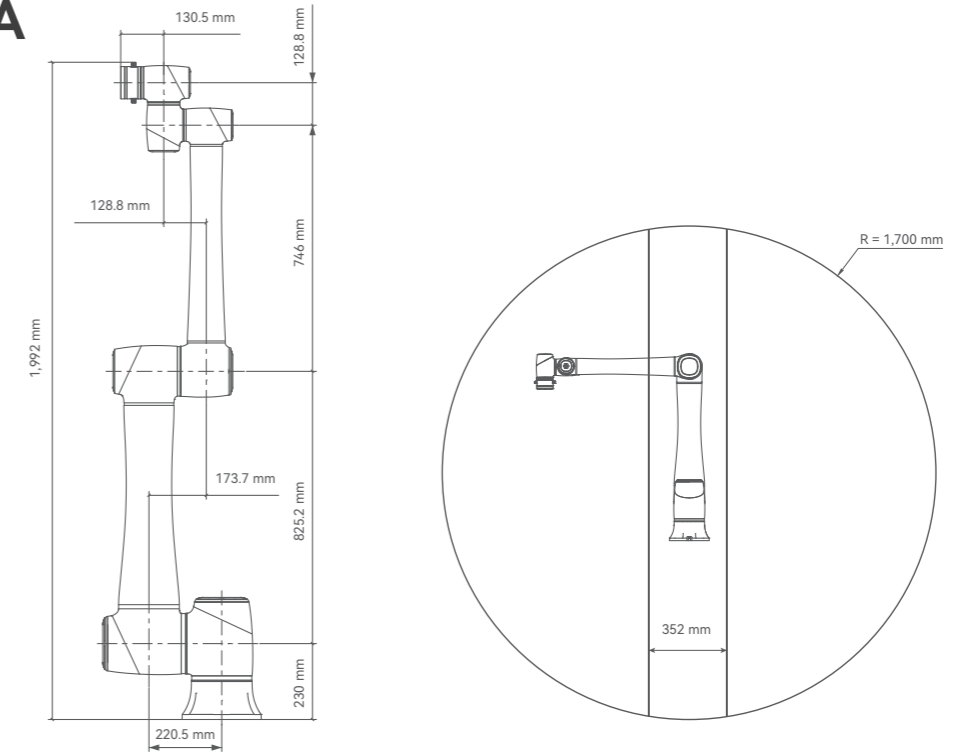

CR16A

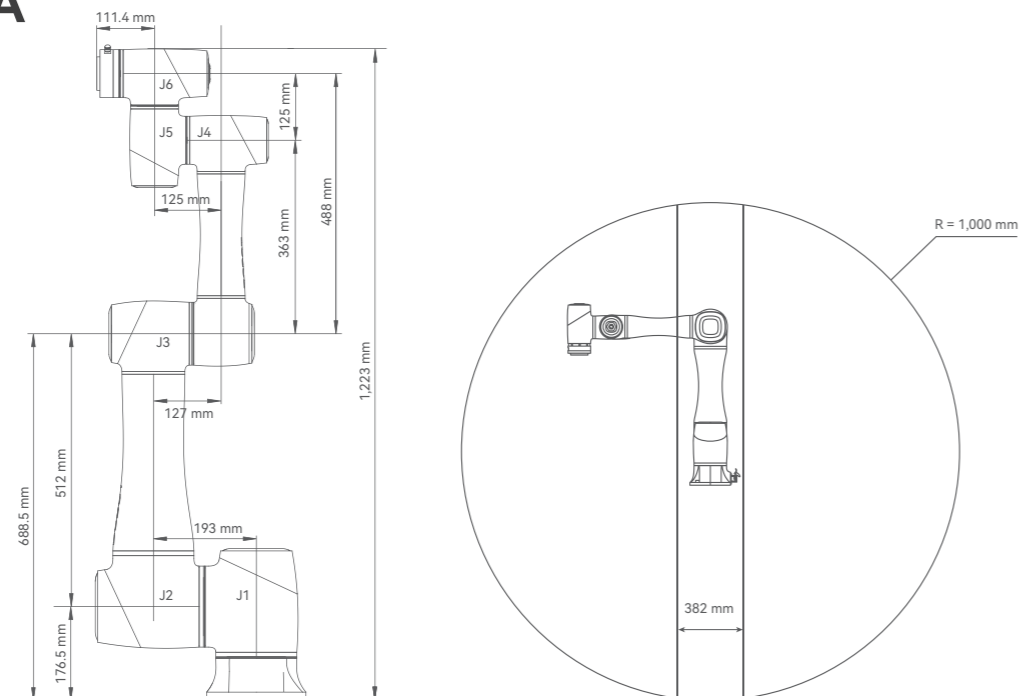

Control Box

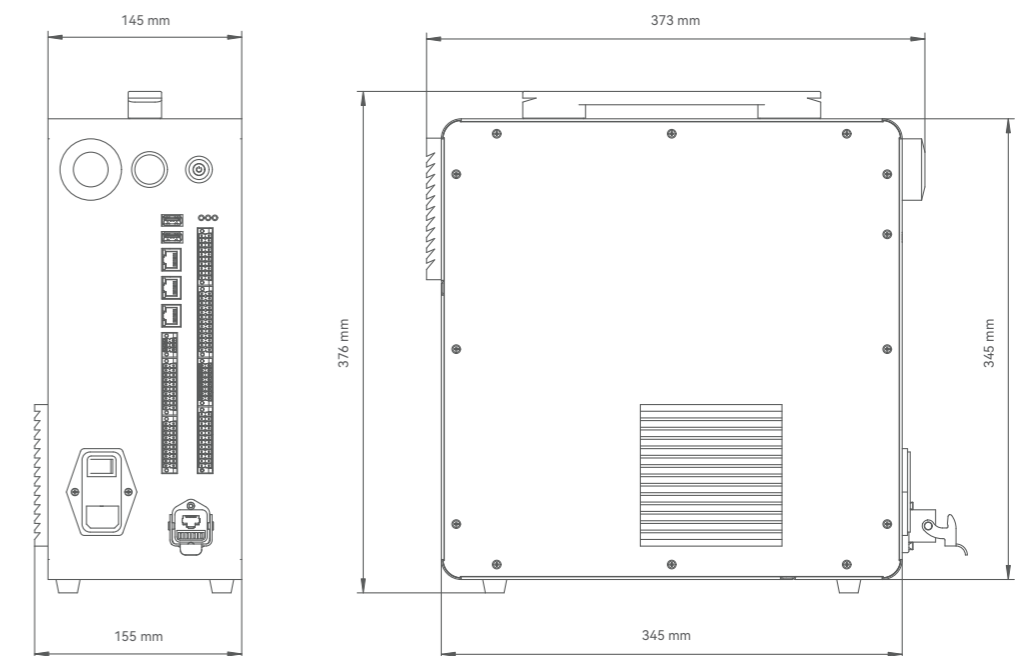

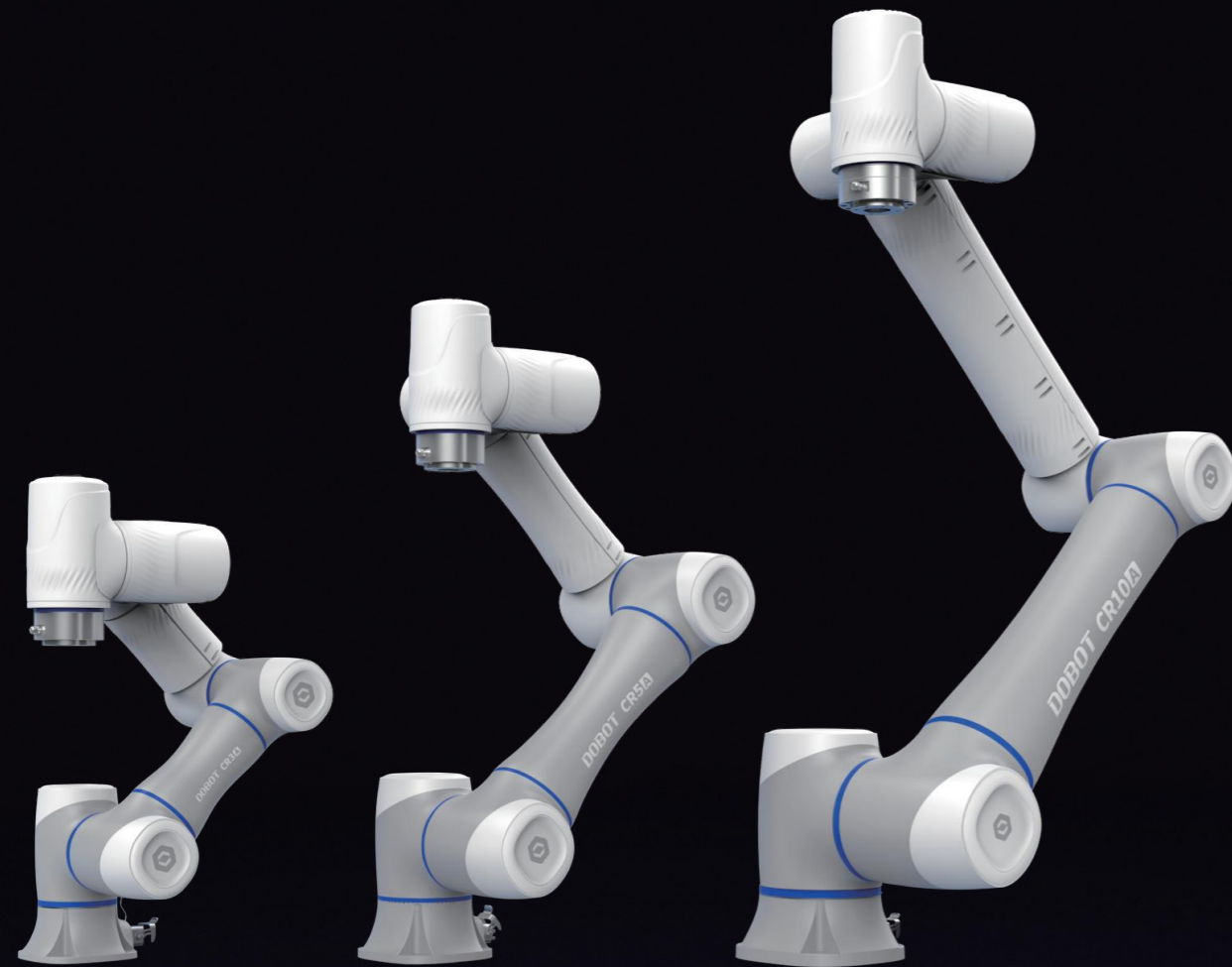

CRAS Series

Pre-collision Detection for Efficiency and Safety

The CRAS series is the upgraded version of the CRA series. It has the same characteristics and performance of the CR series, and is further improved by the addition of the SafeSkin for pre-collision detection to achieve better safety and collaboration efficiency. The CRAS series has 3 kg, 5 kg and 10 kg payloads to offer both safety and efficiency to end users.

15 cm Proactive Protection Range

The CRAS series senses obstacles that come within 15 cm, and performs emergency stop or automatic evasion to avoid damages caused by collisions.



10 ms Instant Response Time

Within 0.01 second after sensing obstacles, it automatically activates reaction procedures predetermined by the users, whether it is to stop or evade. The result is a highly responsive and safe interaction.



360° Safety Protection

The SafeSkin is industry's first wearable accessory made of silicon. It is soft on contact to reduce collision impact. With excellent anti-interference characteristics, the SafeSkin's performance is not affected by intermediate materials such as clothes and plastic gloves. It is wrapped around the robotic arm to offer all-round safety protection.



4 Times Efficiency Gains

With fewer collisions and operation halts, human-machine collaboration speed can be increased to 1 m/s, four times the international standard of 0.25 m/s.



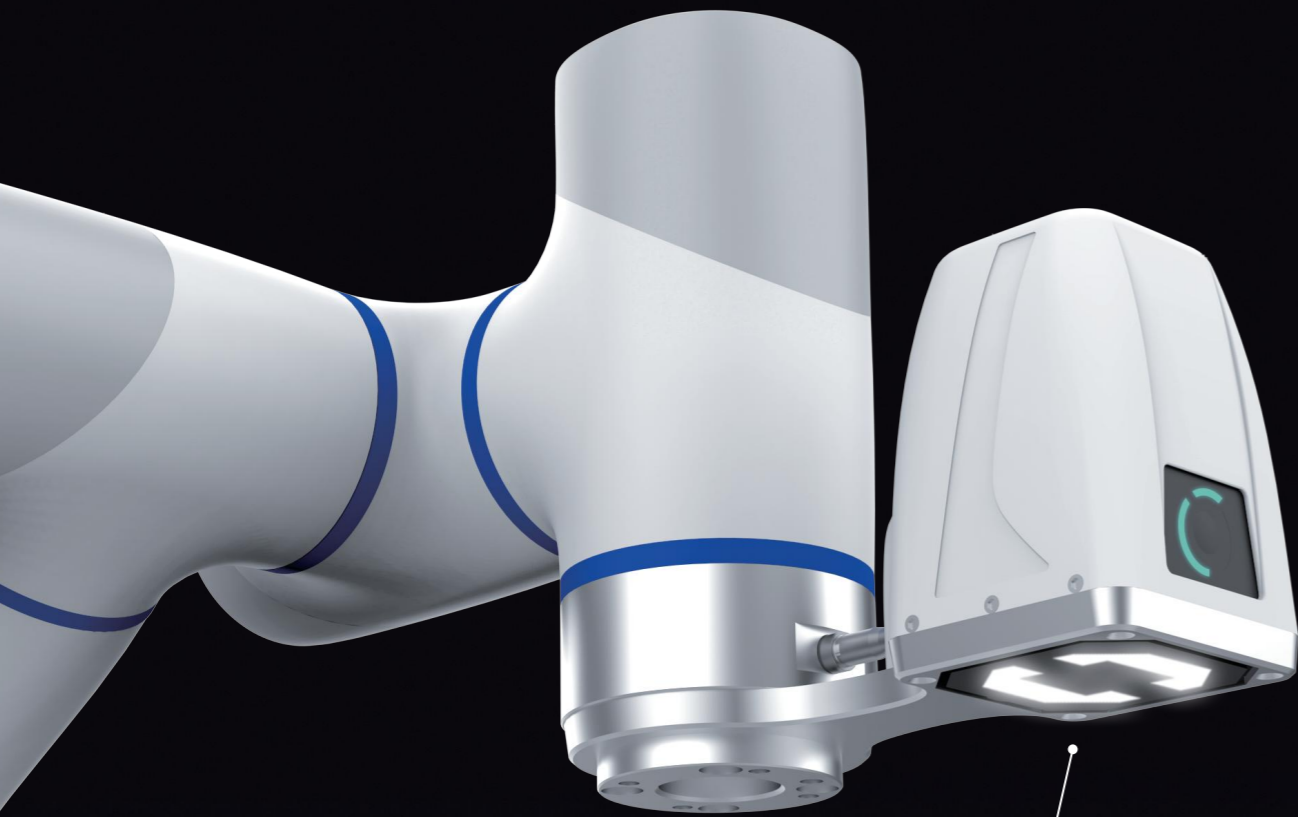

Black & White Smart Camera

12 mm lens, 5 Megapixel HD imaging
14 LED for balanced light source

CRV500

2.5D Vision for Accurate Picking

With a built-in high performance vision system and an operating software, anyone can familiarize themselves easily. The vision kit can carry out tasks such as grabbing, assembly, transportation and even loading and unloading.



Accurate Positioning

Self-developed 2.5D spatial compensation technology with an accuracy of ± 0.5 mm to identify the height and tilt of objects to deal with complex grabbing tasks. For example, in scenarios such as uneven or inclined surfaces, have AMMR robots can carry out tasks accurately.



Quick Deployment

Compatible with DobotStudioPro robot operation software, with guided steps on operation settings and graphical programming, even users with no prior programming knowledge can complete building solutions easily.



Flexible & Expandable

Integrated algorithms to enable object sensing, measurement, text and image identification, fulfilling the majority needs of robotic vision applications.

CRV500 Specifications

Camera	
Sensor Type	CMOS, global shutter
Pixel Size	3.2 μm \times 3.2 μm
Sensor Size	1/1.7"
Resolution	2368 \times 1760
Pixel Format	Mono 8
Color	Black & white
Components	
Lens Connector	M12 mount, mechanical focusing
Focal Length	12.4 mm
Light Source	14 LED: White

Dobot+ Open Ecosystem of Accessories



Dobot+ actively cooperates with ecosystem partners to offer various end effector and peripheral accessories to simplify the deployment process while allowing secondary development for different needs.

- Supports over 100 plug-and-play end effectors for quick automation deployment.
- Provides a one-way RS485 port to end effector and control box each, for flexible third-party accessory expansion.
- Provides standard SDK and rich demo source code for efficient project development.

2D/3D Cameras

	HIKROBOT DS-2CD4065F-(A)(P) Camera		HIKROBOT Industrial Encoder		HIKROBOT Industrial 2D Camera
	ALSONTECH AT-S1000-C		OMRON QX-870 Series Laser Barcode Scanner		COGNEX Vision Systems
	MECHMIND Mech-Eye Industrial 3D Camera		SOLOMON AccuPick 3D		

Force Sensors

	Robotiq FT 300-S Force Torque Sensor		ATI Multi-Axis Force / Torque Sensors		Onrobot Hex 6 Axis Force Torque Sensor
	Kunwei KWR75B Multi-dimensional Force Sensor		Link-touch ST Six-Axis Force Sensor		XJCSSENSOR XJC-3F Adaptive 3-Axis Force Sensor

Grippers

	Tendertouch Soft grippers		ROBOTIQ 2F-85 & 2F-140v		ROBOTIQ 2F-85 & 2F-140
	OnRobot RG2 & RG6		OnRobot 3-Finger Gripper		SCHUNK Co-act EGP Series
	SCHUNK EGH Series		DH-Robotics PGE Series		DH-Robotics PGC Series

Mobile Platforms

	Seer AMB Series		Youibot Trans Mobile Robot
	Standard Robots OASIS AMRs		AGILE.X HUNTER 2.0

Solutions



We have developed specially process package software for screwdriving, welding and palletizing. Through simple setups, automation processes can be built. This significantly reduce the amount of time and labor cost needed for project development. These process packages work with ecosystem accessories, users can choose the right accessories for their



Welding Solution

Setup arc/laser welding applications quickly with the welding process package and welding machine.



Deploy in 30 Minutes

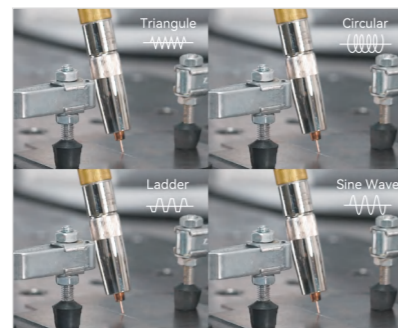

Supports Various Arc Patterns



Collision Protection Without Fence



Screwdriving Solution

Screwdriving process package and electric screwdriver allow flexible customization of various screwdriving tasks.



Simple Setup, Easy to Familiarize



Calibration in 2 Steps

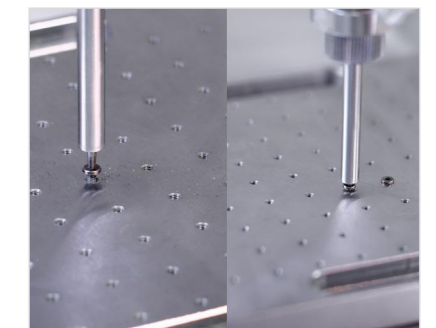

Consistent Quality & Capable Performance



Palletizing Solution

Complete task building in 2 to 4 hours with plug-and-play accessories and the palletizing process package.



Easily Create Automation Processes

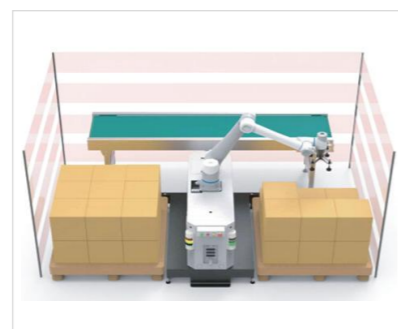

Supports External Light Curtains



Remote Tracking of Live Status



AMMR Solution

Collaborative robot and AMR work together to carry out tasks such as transportation, loading and unloading between multiple stations and inspections.



Laser SLAM Navigation

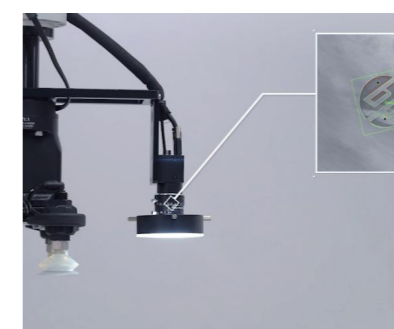

2.5D Vision

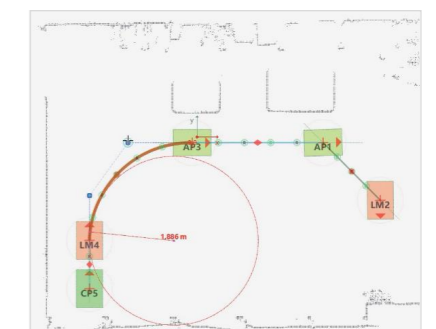

Completes Route Planning in 5 Minutes

Diverse Application Scenarios



The CRA series has 3 kg, 5 kg 10 kg, 12 kg, 16 kg and 20 kg payloads to offer both safety and efficiency to end users. Covers over 15 major industries including consumer electronics, automotive, semiconductor, food & beverage, chemical, healthcare and retail.



PCB Board Loading & Unloading



PCB Board Burn-in Transportation



Semiconductor Plastic Packaging Loading and Unloading



Loading & Unloading CNC Machine Tools (SafeSkin)



Machine Tools Loading & Unloading

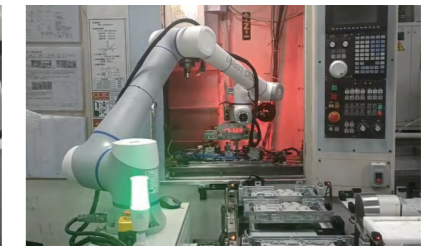

Loading & Unloading by AMMR

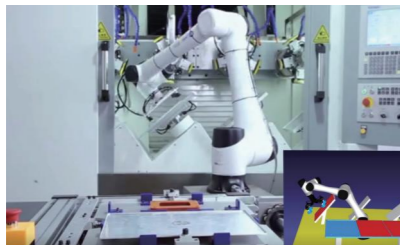

Laptop Back Case Polishing, Loading & Unloading



Electronic Parts Inspection



Automotive Parts Assembly

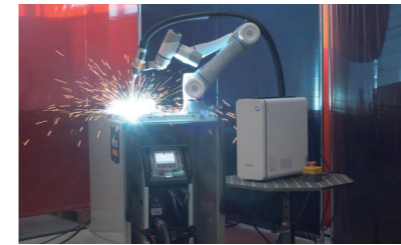

Metal Workpieces Processing



Depalletize Plastic Bottles



Loading & Unloading Plastic Caps



Automotive Oil Pipe Joint Installation

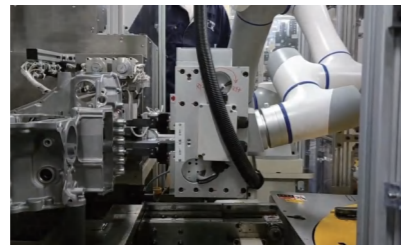

Gearbox Screwdriving



Windshield Gluing



Inspection of Dangerous Chemicals



Inspection of Toilet Bowls



Eyeglasses Polishing

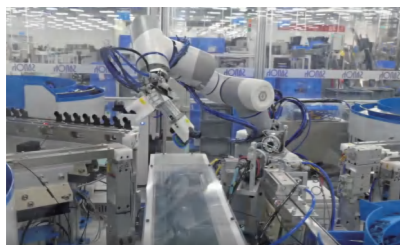

Automotive Joint Sealing Ring Installation



Energy Storage Screwdriving



Loading & Unloading New Energy Battery

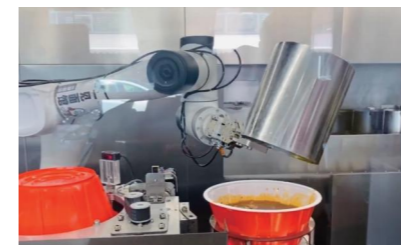

Robot Noodle Store



Latte Art Coffee Stand



Laboratory Assistant